

Manual

Cryogenic Mixer Mill CryoMill



Translation



Copyright

© Copyright by
Retsch GmbH
Retsch-Allee 1-5
42781 Haan
Germany

Table of Contents

1	Notes on the Manual	6
1.1	Explanations of the Safety Instructions	7
1.2	General Safety Instructions	8
1.3	Repairs.....	9
2	Confirmation	10
3	Technical Data	11
3.1	Protective Equipment.....	11
3.2	Emissions.....	11
3.3	Degree of Protection.....	11
3.4	Rated Power	12
3.5	Dimensions and Weight.....	12
3.6	Required Floor Space.....	12
4	Packaging, Transport and Installation	13
4.1	Packaging	13
4.2	Transport.....	13
4.3	Temperature fluctuations and condensed water	13
4.4	Conditions for the Installation Site	13
4.5	Installation of the Device.....	14
4.6	Removing the Transportation Lock.....	15
4.7	Type Plate Description.....	19
4.8	Electrical Connection	20
4.9	Connecting the Coolant Feed	21
4.10	Removing the liquid nitrogen feed line	25
4.11	Cold air outlet.....	25
4.12	Mounting the exhaust hose.....	26
5	Operating the Device	27
5.1	Use of the Device for the Intended Purpose.....	27
5.2	Operating elements and displays	28
5.3	Summary table of device parts	29
5.4	Operating Controls, Displays and Functions	30
5.5	Inserting the Grinding Jar	32
5.5.1	Inserting and removing CryoMill special grinding jar	32
5.5.2	Inserting the cooling jacket sealing plug	36
5.5.3	Insert the adapter for 4/2 x 5 ml grinding jar	36
5.5.4	Insert the adapter for 6 / 4 / 2 x 2-ml Eppendorf reaction vial	37
5.6	Explanations of the grinding cycles	38
5.6.1	Grinding without cooling	38
5.6.2	Grinding with cooling	39
5.7	Programme Mode	41
5.7.1	Grinding without program	41
5.7.2	Grinding with program	41
5.7.2.1	Selection of a program.....	41
5.7.2.2	Display of the program grinding parameters	41
5.7.2.3	Create/change a program.....	42
5.7.2.4	Delete program	42
5.8	Setting grinding cycles.....	42
5.9	Setting the precooling time	43
5.9.1	Precooling with definable precooling time	43
5.9.2	Automatic precooling	43
5.10	Setting the grinding time	44
5.11	Setting the duration of intermediate cooling	44
5.12	Setting the grinding frequency	45
5.13	Starting the grinding process.....	46

5.14	Interrupting and continuing the grinding process	46
5.14.1	Pausing grinding	46
5.14.2	Cancelling grinding	47
5.15	Stopping the grinding process	47
5.16	Operating hours display	48
5.17	Operating software display	49
5.18	Replacing the machine fuses.....	50
6	Working instructions.....	51
6.1	General	51
6.2	The grinding process	51
6.3	Quantities of sample material and feed sizes	52
6.4	Working instructions	53
7	Safety functions and fault display	54
7.1	Error Messages	54
8	Cleaning, Wear and Maintenance	55
8.1	Cleaning.....	55
8.2	Wear	55
8.3	Wearing parts	55
8.4	Maintenance	55
8.5	Checks.....	56
9	Safety and occupational health instructions.....	57
9.1	General	57
9.2	Safety instructions on the handling of liquid nitrogen	58
9.3	Oxygen deficiency	58
9.3.1	Dangers	58
9.3.2	Causes.....	58
9.3.3	Recommendations	59
9.3.4	General conduct in the case of an accident	59
9.4	Cryogenic burns.....	59
9.4.1	Dangers	59
9.4.2	Causes.....	59
9.4.2.1	Burns through splashes	59
9.4.2.2	Burns through contact.....	60
9.4.3	Recommendations	60
9.4.4	General rules of conduct for splashes with liquid nitrogen	60
9.4.4.1	To the eyes	60
9.4.4.2	On the skin.....	60
9.5	Danger of explosion.....	60
9.5.1	Dangers	60
9.5.2	Causes.....	60
9.5.3	Recommendations	61
9.5.4	General conduct in the case of an accident	61
9.6	Oxygen enrichment.....	61
9.6.1	Dangers	61
9.6.2	Causes.....	61
9.6.3	Recommendations	61
9.7	Surrounding area of the machine	62
9.7.1	Rooms.....	62
10	Disposal.....	63
11	Index	64

1 Notes on the Manual

This Manual provides technical guidelines for the safe operation of the device. Read this Manual through carefully before installing, putting into service and operating the device. Reading and understanding this Manual is essential for handling the device safely and as intended.

This Manual does not contain any repair instructions. Please contact your supplier or contact Retsch GmbH directly if anything is unclear or you have questions about these guidelines or the device, or in the case of any faults or necessary repairs.

You can find further information about your device at <http://www.retsch.com> on the pages for the specific device concerned.

Amendment status:

The document amendment 0005 of the "Cryogenic Mixer Mill CryoMill" manual has been prepared in accordance with the Machinery Directive 2006/42/EC.

Changes

Subject to technical changes.

Copyright

Disclosure or reproduction of this documentation, use and disclosure of its contents are only permitted with the express permission of Retsch GmbH. Infringements will result in damage compensation liability.

1.1 Explanations of the Safety Instructions

In this Operating Manual we give you the following safety warnings

Serious injury may result from failing to heed these safety warnings. We give you the following warnings and corresponding content.

 **WARNING**

Type of danger / personal injury

Source of danger

- Possible consequences if the dangers are not observed.
 - **Instructions on how the dangers are to be avoided.**
-

We also use the following signal word box in the text or in the instructions on action to be taken:

 **WARNING**

Moderate or mild injury may result from failing to heed these safety warnings. We give you the following warnings and corresponding content.

 **CAUTION**

Type of danger / personal injury

Source of danger

- Possible consequences if the dangers are not observed.
 - **Instructions on how the dangers are to be avoided.**
-

We also use the following signal word box in the text or in the instructions on action to be taken:

 **CAUTION**

In the event of possible **property damage** we inform you with the word “Instructions” and the corresponding content.

NOTICE

Nature of the property damage

Source of property damage

- Possible consequences if the instructions are not observed.
 - **Instructions on how the dangers are to be avoided.**
-

We also use the following signal word in the text or in the instructions on action to be taken:

NOTICE

1.2 General Safety Instructions



CAUTION

Read the Operating Manual

Non-observance of these operating instructions

- The non-observance of these operating instructions can result in personal injuries.
- **Read the operating manual before using the device.**
- **We use the adjacent symbol to draw attention to the necessity of knowing the contents of this operating manual.**



Target group : All persons concerned with the machine in any form

This machine is a modern, high performance product from Retsch GmbH and complies with the state of the art. Operational safety is given if the machine is handled for the intended purpose and attention is given to this technical documentation.

You, as the owner/managing operator of the machine, must ensure that the people entrusted with working on the machine:

- have noted and understood all the regulations regarding safety,
- are familiar before starting work with all the operating instructions and specifications for the target group relevant for them,
- have easy access always to the technical documentation for this machine,
- and that new personnel before starting work on the machine are familiarised with the safe handling of the machine and its use for its intended purpose, either by verbal instructions from a competent person and/or by means of this technical documentation.

Improper operation can result in personal injuries and material damage. You are responsible for your own safety and that of your employees.

Make sure that no unauthorised person has access to the machine.



CAUTION

Changes to the machine

- Changes to the machine may lead to personal injury.
- **Do not make any change to the machine and use spare parts and accessories that have been approved by Retsch exclusively.**

NOTICE

Changes to the machine

- The conformity declared by Retsch with the European Directives will lose its validity.
- You lose all warranty claims.
- **Do not make any change to the machine and use spare parts and accessories that have been approved by Retsch exclusively.**

1.3 Repairs

This operating manual does not contain any repair instructions. For your own safety, repairs may only be carried out by Retsch GmbH or an authorized representative or by Retsch service engineers.

In that case please inform:

The Retsch representative in your country
Your supplier
Retsch GmbH directly

Your Service Address:

2 Confirmation

This operating manual contains essential instructions for operating and maintaining the device which must be strictly observed. It is essential that they be read by the operator and by the qualified staff responsible for the device before the device is commissioned. This operating manual must be available and accessible at the place of use at all times.

The user of the device herewith confirms to the managing operator (owner) that (s)he has received sufficient instructions about the operation and maintenance of the system. The user has received the operating manual, has read and taken note of its contents and consequently has all the information required for safe operation and is sufficiently familiar with the device.

As the owner/managing operator you should for your own protection have your employees confirm that they have received the instructions about the operation of the machine.

I have read and taken note of the contents of all chapters in this operating manual as well as all safety instructions and warnings.

User

Surname, first name (block letters)

Position in the company

Signature

Service technician or operator

Surname, first name (block letters)

Position in the company

Place, date and signature

3 Technical Data

3.1 Protective Equipment

The grinding chamber of the CryoMill laboratory mill is surrounded by a stable hood. It is only possible to start the device when the hood is closed.

3.2 Emissions

Noise values:

The noise values are also influenced by the properties of the sample material.

No-load operation:

Emission value with regard to workplace L_{pAeq} = 61,4 dB(A)

Example 1:

Emission value with regard to workplace L_{pAeq} = 75,2 dB(A)

Operating conditions:

Receptacle:	1 50ml steel grinding jar
Grinding component:	1 25mm steel ball each
Feed material:	Quartz gravel particles approx. 4.0 – 6.0mm
Feed quantity:	8ml
Frequency:	30 Hz

Example 2:

Emission value with regard to workplace L_{pAeq} = 66,3 dB(A)

Operating conditions:

Receptacle:	4 5ml steel grinding jar
Grinding component:	2 8mm tungsten carbide balls each
Feed material:	Quartz gravel particles approx. 1.0 – 1.5mm
Feed quantity:	1.5ml
Frequency:	30 Hz



Hearing loss

A high sound level may occur depending on the type of material, the number of balls used, the set grinding frequency and the grinding time.

- Excess noise in terms of intensity and duration can lead to impairments or permanent damage to hearing.
- **Ensure you take suitable soundproofing measures or wear hearing protection.**



3.3 Degree of Protection

IP30

3.4 Rated Power

260 watts

3.5 Dimensions and Weight

Height : 373 to approx. 630 mm with open hood

Width: 395 mm

Depth: 577 mm/ 710mm with exhaust hose

Weight: approx. 46 kg without grinding jar

3.6 Required Floor Space

Installation surface: 620 mm x 720 mm

4 Packaging, Transport and Installation

4.1 Packaging

The packaging is designed for the transport route. It corresponds to generally acceptable packaging guidelines.

NOTICE

Storage of packaging

- In the event of a complaint or return, your warranty claims may be endangered if the packaging is inadequate or the machine has not been secured correctly.
- **Please keep the packaging for the duration of the warranty period.**

4.2 Transport

NOTICE

Transport

- Mechanical or electronic components may be damaged.
- **The machine may not be knocked, shaken or thrown during transport.**

4.3 Temperature fluctuations and condensed water

NOTICE

Temperature fluctuations

The machine may be subject to strong temperature fluctuations during transport (e.g. aircraft transport)

- The resultant condensed water may damage electronic components.
- **Protect the machine from condensed water.**

4.4 Conditions for the Installation Site

Ambient temperature: 5°C to 40°C

NOTICE

Ambient temperature

- Electronic and mechanical components may be damaged and the performance data alter to an unknown extent.
- **Do not exceed or fall below the permitted temperature range of the machine (5°C to 40°C / ambient temperature).**

Atmospheric humidity:

Maximum relative humidity 80% at temperatures up to 31°C, decreasing linearly up to 50% relative humidity at 40°C

*NOTICE***Atmospheric humidity**

- Electronic and mechanical components may be damaged and the performance data alter to an unknown extent.
 - **Do not exceed the admissible range for atmospheric humidity.**
-

4.5 Installation of the Device

Installation height: maximum 2000 m above sea level

*NOTICE***Property damage**

A very cold vapour plume escapes from the nitrogen gas outlet.

- The vapour plume can greatly cool objects. This is why the humidity in the air condenses.
 - **The area above the nitrogen gas outlet (B) up to the ceiling must be kept free.**
-

*NOTE***Installation**

- Depending on the operating status of the mill, there may be slight vibrations.
 - **Place the mill on an even, flat and balanced supporting surface only. The supporting surface must be stable and must not vibrate.**
-

*NOTICE***Installation of the machine**

- It must be possible to disconnect the machine from the mains at any time.
 - **Install the machine such that the connection for the mains cable is easily accessible.**
-

4.6 Removing the Transportation Lock

NOTICE

N1.0018

Transportation lock

Transport without transportation lock, or operation with transportation lock

- Mechanical components may be damaged.
- **Only transport the device with mounted transportation lock.**
- **Do not operate the device with built-in transportation lock.**

- Place the device on a stable table.
- Pull the device carefully beyond the edge of the table in order to be able to reach the screw (TA).

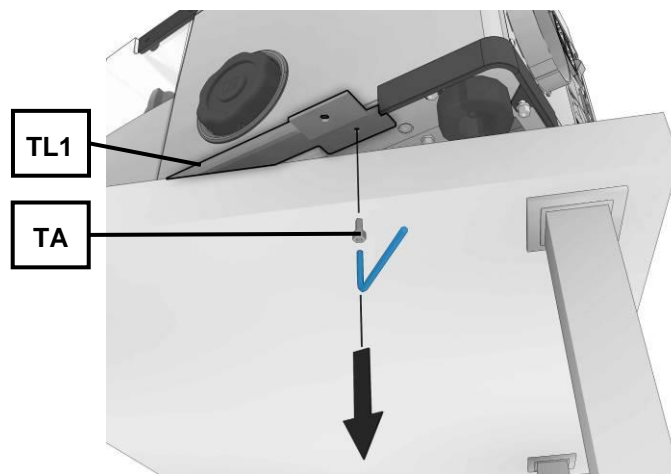

Fig. 1: Removing the transport bracket

- Remove the screw (TA) using an Allen key.

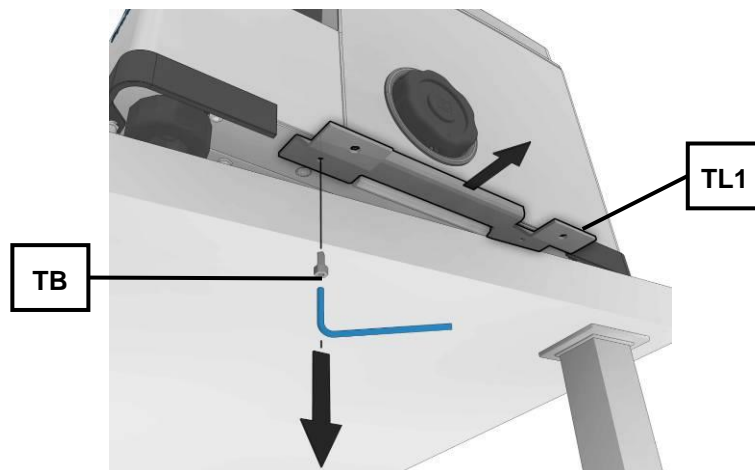

Fig. 2:

- Pull the device into the position shown in order to be able to remove the screw (TB).
- Remove the second screw (TB) and remove the transport bracket (TL1).

NOTICE

Keep the transport brackets, screws and transport lock for future transport!

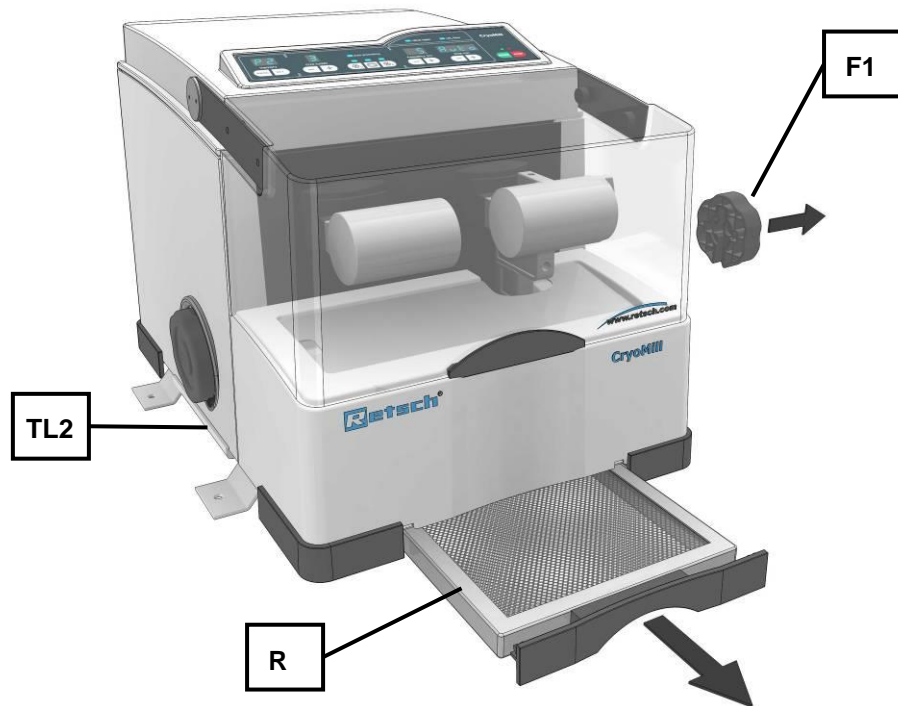

Fig. 3: Pulling out the condensation collecting filter

- Pull the condensation collecting filter (R) completely out of the device.
- Remove the opening aids (F1) on the side on which you have removed the transport bracket (TL1).
- Place a soft, clean mat (U) next to the device.
- Tilt the device onto the side on which the transport bracket (TL1) has been removed.

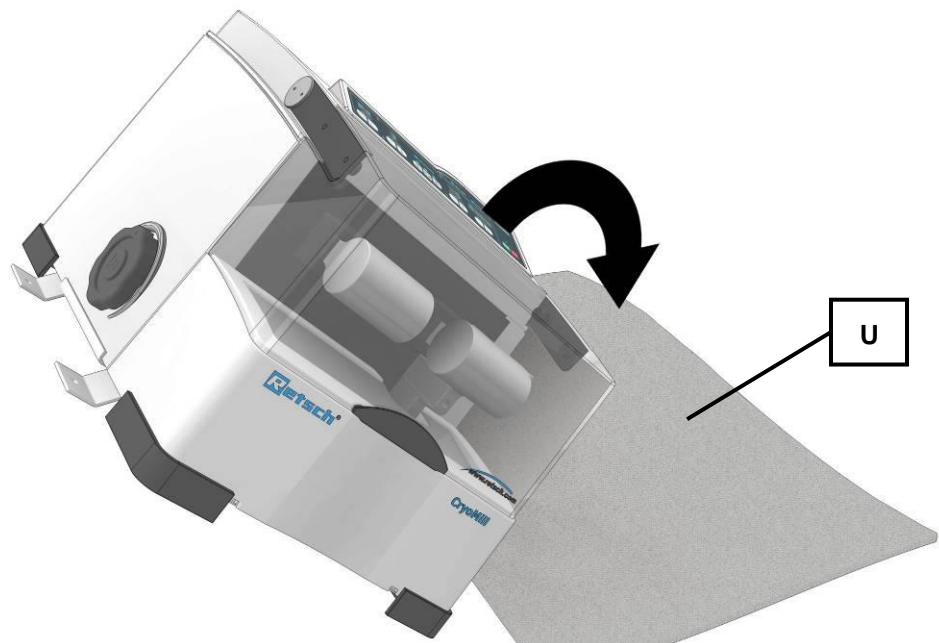

Fig. 4: Tilting the device onto its side

The transport lock (**TS**), which is labelled with an arrow, is situated on the underneath of the device.

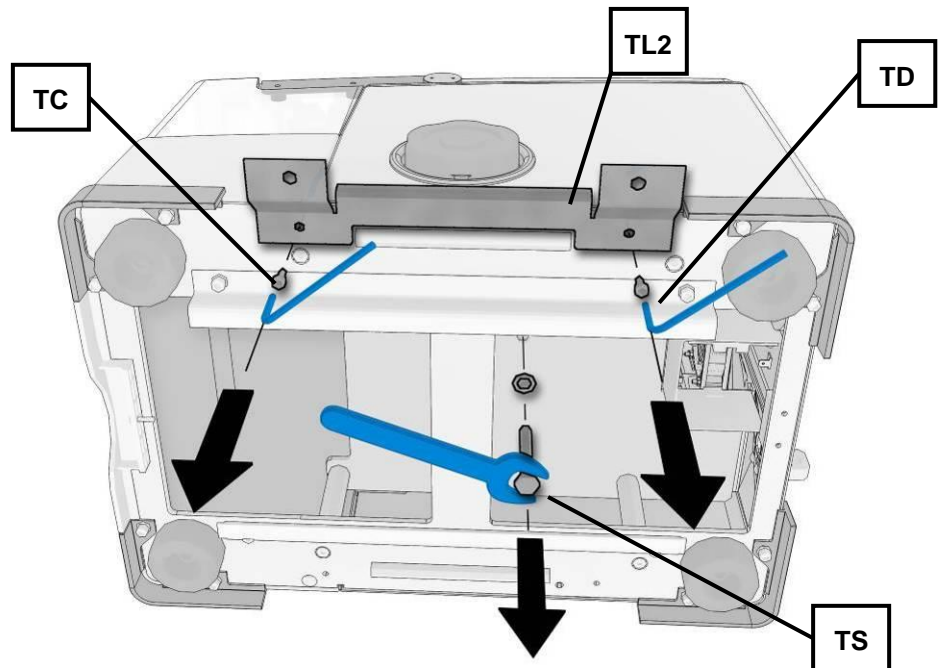

Fig. 5: Removing the transport lock

- Loosen and remove the screw (**TS**).
- Unscrew the two screws (**TC**) and (**TD**).
- Remove the transport bracket (**TL2**).

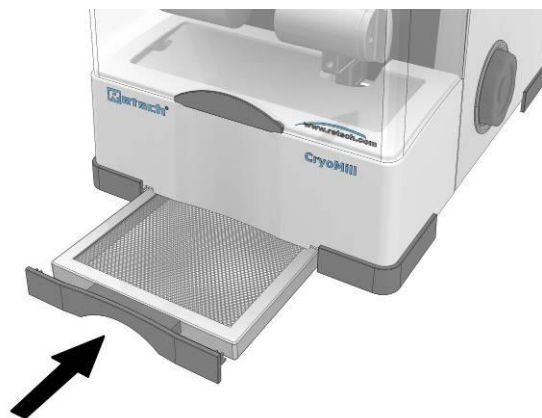

Fig. 6:

- Re-insert the condensation collecting filter (**R**).

NOTICE

Keep the transport brackets, screws and transport lock for future transport!

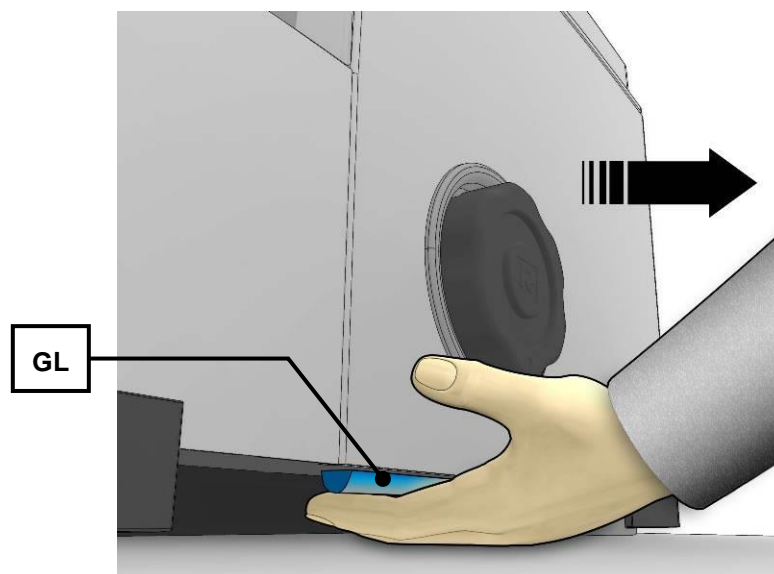

Fig. 7: Grip

A grip (**GL**) is situated underneath both sides of the device

- Use the grip (**GL**) to move the device.

4.7 Type Plate Description

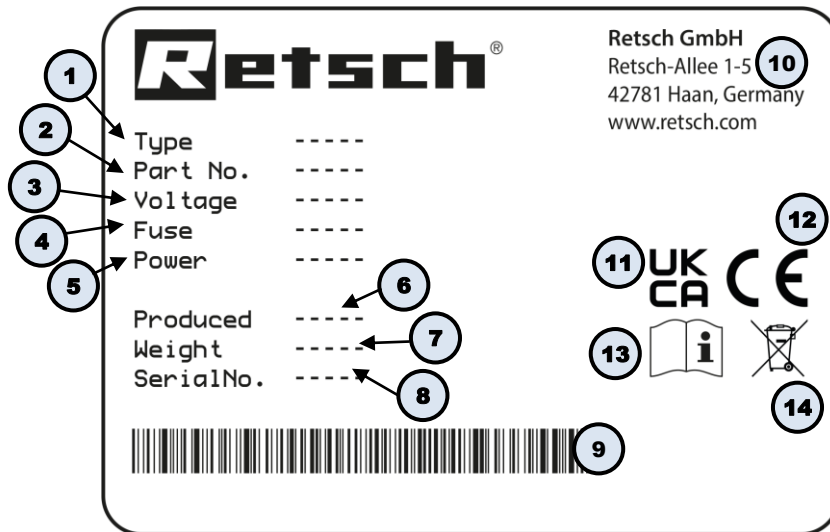

Fig. 8: Type plate

- 1 Device designation
- 2 Part number
- 3 Power version, Mains frequency
- 4 Fuse type and fuse strength
- 5 Capacity, Amperage
- 6 Year of production
- 7 Weight
- 8 Serial number
- 9 Bar code
- 10 Manufacturer's address
- 11 UKCA marking
- 12 CE marking
- 13 Safety warning: Read the manual
- 14 Disposal label

① In the case of queries please provide the device designation (1) or part number (2), as well as the serial number (8) of the device.

4.8 Electrical Connection

 **WARNING**

When connecting the power cable to the mains supply, use an external fuse that complies with the regulations applicable to the place of installation .

- Please check the type plate for details on the necessary voltage and frequency for the device.
- Make sure the levels agree with the existing mains power supply.
- Use the supplied connection cable to connect the device to the mains power supply.

The external fuse must be at least T6.3A (230V) T8A (100/120V).

 **WARNING**

W0002

Danger to life through electric shock

- An electric shock can cause burns and cardiac arrhythmia, as well as respiratory failure and cardiac arrest.
- **Never use a damaged power cable to connect the device to the mains.**
- **Check the power cable and plug for any damage before use**

NOTICE

Electrical connection

- Mechanical or electronic components may be damaged.
 - **Please observe the information on the type plate.**
-

4.9 Connecting the Coolant Feed

 **CAUTION**

Blocked pipe

Ice formation

- Water vapour from the environment may condense on parts of the device when the climate in the room or area has been altered due to transportation or changes in the air conditioning. This applies in particular following transportation of the device by plane.
- Ice or foreign bodies may block the pipes and then lead to malfunctions.

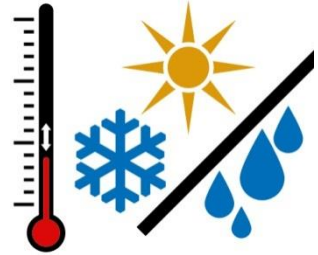

- **Keep the cooling system and inlet hose dry and free from foreign bodies.**
 - **Do not use the grinding jar if it is damp or covered with frost.**
 - **Place the cooling jacket seal (KA) if the device is not going to be used for a longer period of time.**
 - **Keep climatic conditions in the room where the device is operated as constant as possible.**
 - **Allow a 24-hour acclimatisation period following any changes to the climatic conditions for the device.**
 - **The device should not be operated unsupervised.**
-

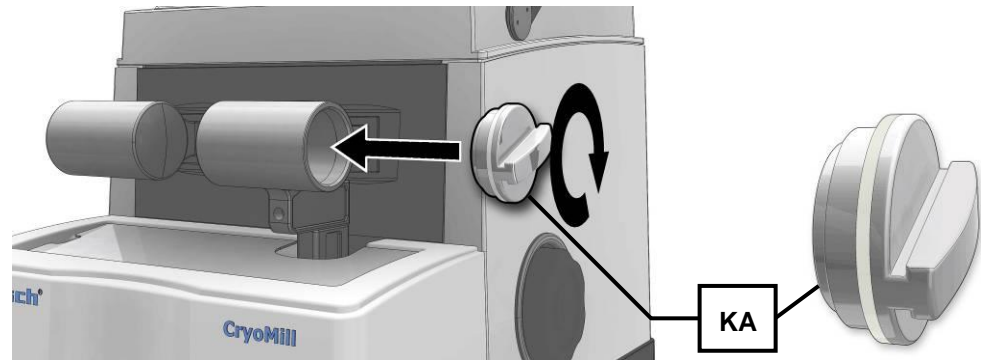

Fig. 9: Cooling jacket seal

NOTICE

Damage to the machine

Incorrect cooling agent

- The use of cooling agents other than liquid nitrogen will cause the cooling system to lose its leak tightness.
- **Only liquid nitrogen (LN2) may be used as cooling agent with this device.**

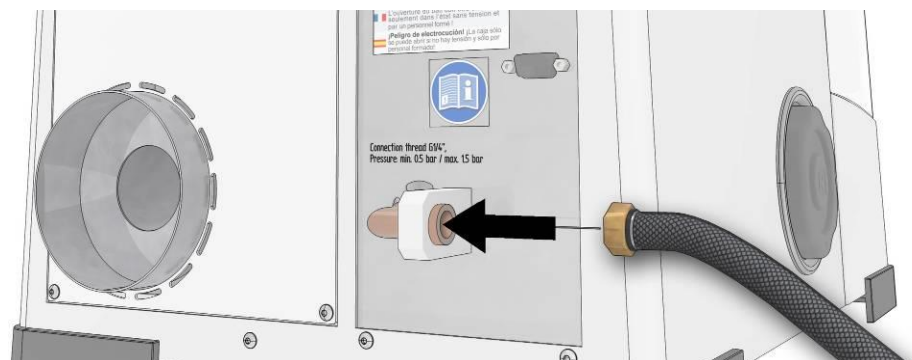

Fig. 10: Connecting the cooling agent supply

NOTICE After refilling the liquid nitrogen container, wait at least 12 hours (until the hose is completely dry) before connecting the container to the CryoMill. Condensed air humidity and ice crystals inside the hose might block the valves.

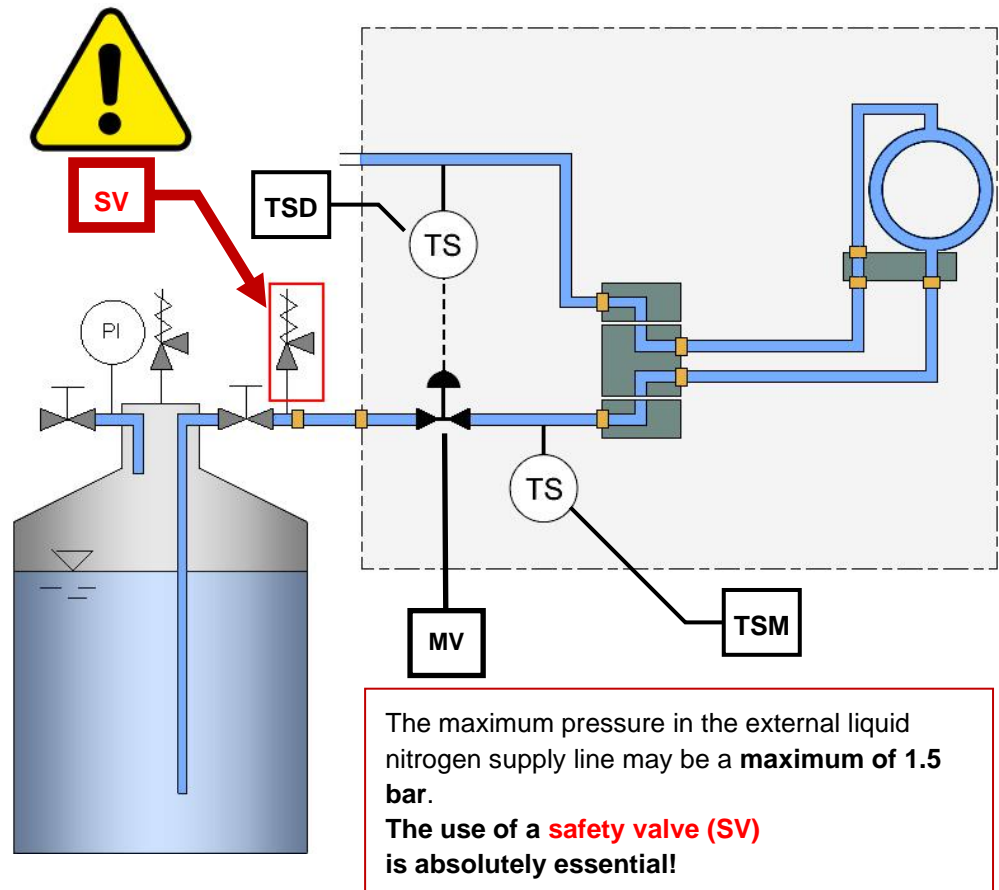

Fig. 11: Diagram of the cooling system

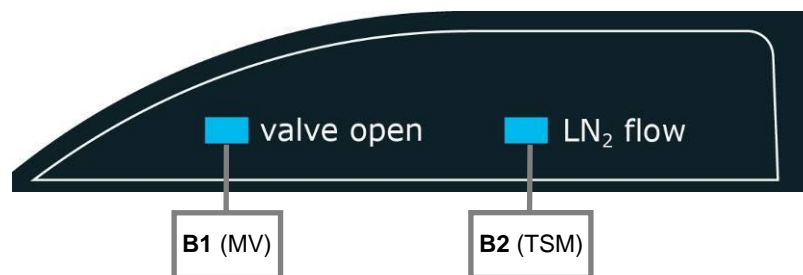

Fig. 12: LED displays

The temperature sensor (**TSD**) in the LN₂ outlet controls the solenoid valve (**MV**). The LED (**B1**) lights up when the solenoid valve (**MV**) is open.

The temperature sensor (**TSM**), which is downstream of the solenoid valve, registers whether liquid nitrogen is flowing into the CryoMill. The LED (**B2**) lights up when liquid nitrogen flows into the cooling system.

CAUTION

The device must not be moved in a cryogenic state and no additional forces may act on the cooling agent connection (**N**). The cooling agent inlet hose must not be moved while the device is in a cryogenic state.

 **CAUTION****Risk of injury and danger of frostbite**

Bursting of the inlet hose.

- Depending on the operating state of the device, liquid nitrogen may be enclosed in the supply line. When heated this may lead to the inlet hose bursting.
- **The maximum pressure in the external liquid nitrogen supply line may be a maximum of 1.5 bar. The use of a safety valve is absolutely essential!**

The connection for the liquid nitrogen (LN2) is a G 1/4 inch threaded connector .
The operating pressure in the liquid nitrogen supply line should be at least 0.5 bar. The lower the pressure of the liquid nitrogen supply line, the longer the precooling takes. At 0.5 bar supply line pressure and with the system at room temperature, precooling requires approx. 10 minutes. Depending on the application, you can execute up to 4 grinding operations with 10 litres of liquid nitrogen.

Throughout the entire duration of cooling, the air humidity in the chamber condenses on all cooled parts as a layer of ice .

After cooling this condensation drips into the collecting filter and evaporates.

 **CAUTION**

1.V0070

Risk of injury and danger of frostbite

Uncontrolled escape of liquid nitrogen

- There is a risk of injury in the event of an uncontrolled escape of liquid nitrogen.
- **Stop the liquid nitrogen supply line immediately!**

NOTICE

Depending on the ambient temperature, air humidity and duration of use, small quantities of water may drip from the collecting filter.

4.10 Removing the liquid nitrogen feed line



Abb. 13: Removing the liquid nitrogen feed line

CAUTION

Before you remove the liquid nitrogen feed line, the pressure must be relieved for safety reasons.

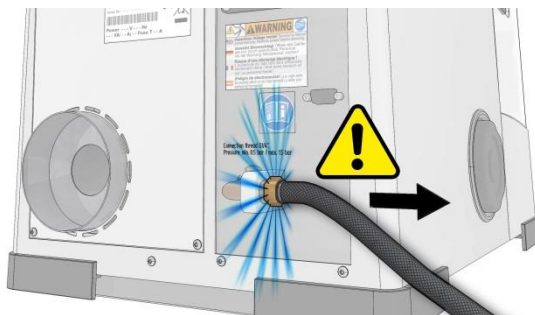

Abb. 14: pressure relief

- Press and hold the pre-cooling button (**B10**) directly followed by the START button (**B13**). Hold down both buttons for two seconds.
- As long as you keep the keys depressed, the solenoid valve will remain open.

4.11 Cold air outlet

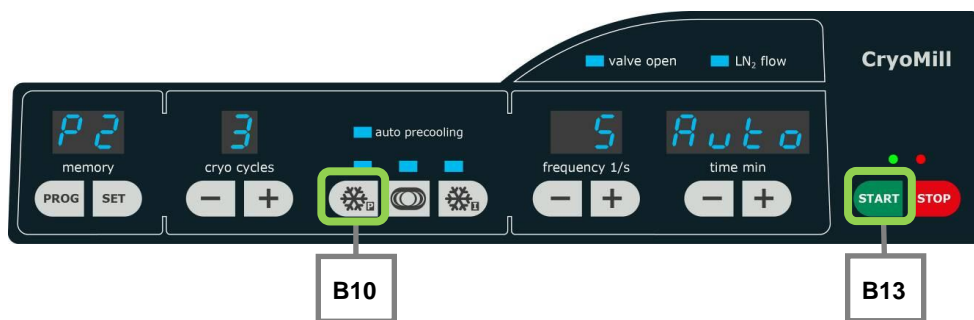
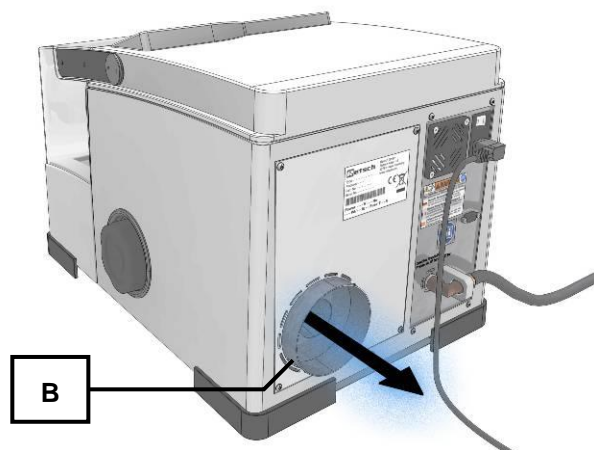

Fig. 15: Outlet for gaseous nitrogen (**B**)

CAUTION

Risk of injury to eyes and skin

Outlet for gaseous nitrogen

- Liquid nitrogen has a temperature of -196 °C and can cause burn-like injuries or frostbite in the case of contact with the skin or eyes.
- **Do not keep any parts of the body in front of the outlet for gaseous nitrogen (B).**

4.12 Mounting the exhaust hose

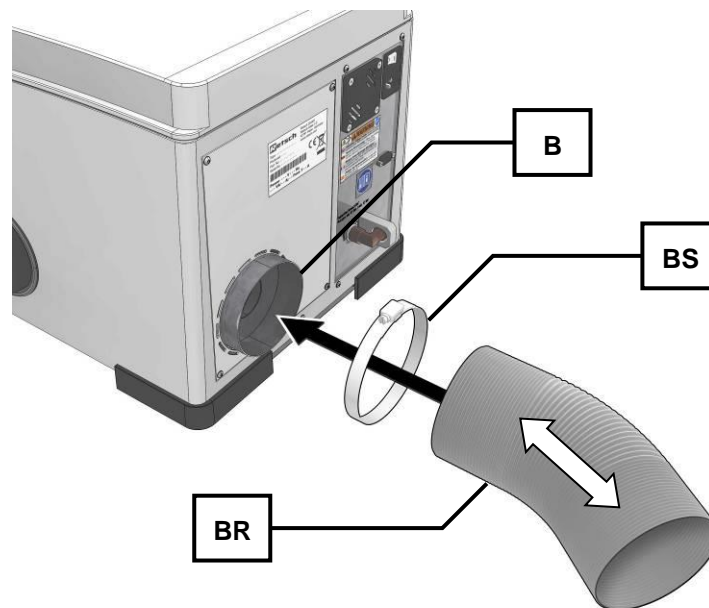

Fig. 16: Exhaust hose

- Fasten the exhaust hose (**BR**) with the clamp (**BS**) to the outlet (**B**).
- The exhaust hose can be extended up to 1 m

5 Operating the Device

5.1 Use of the Device for the Intended Purpose

Target group: operating company, operator

Name of machine model: CryoMill

This machine is a laboratory device and is suitable for the particularly gentle grinding and homogenisation of heat-sensitive, soft, fibrous, hard and brittle materials in a dry and wet state. The CryoMill is designed exclusively for special grinding jars with screw-top lids (no standard grinding jars) with steel jacket. It is used for the fast pulverization of up to six samples simultaneously (depending on the type of grinding jar).

Available grinding jar volumes :

- 50ml;
- 35ml;
- 25ml;
- 10ml;
- 4 x 5ml including adapter; and
- 6 x 2ml Eppendorf vials.

The closed grinding system guarantees complete recovery of the samples . Due to the extremely short grinding time and the high final fineness of the grinding sample, the CryoMill is also ideally suitable for sample preparation for all spectral analyses.

Final fineness levels of up to 5 µm can be achieved depending on the grinding time and the specific properties of the sample material.

The optimal grinding jar filling is generally 1/3 of the grinding jar volume. Voluminous materials such as wool, leaves, grasses and similar are exceptions to this. A fill level of 70 - 80% is necessary here.

NOTICE

Area of use of the machine

- This machine is a laboratory machine designed for 8-hour single-shift operation.
 - **This machine may not be used as a production machine nor is it intended for continuous operation.**
-

5.2 Operating elements and displays

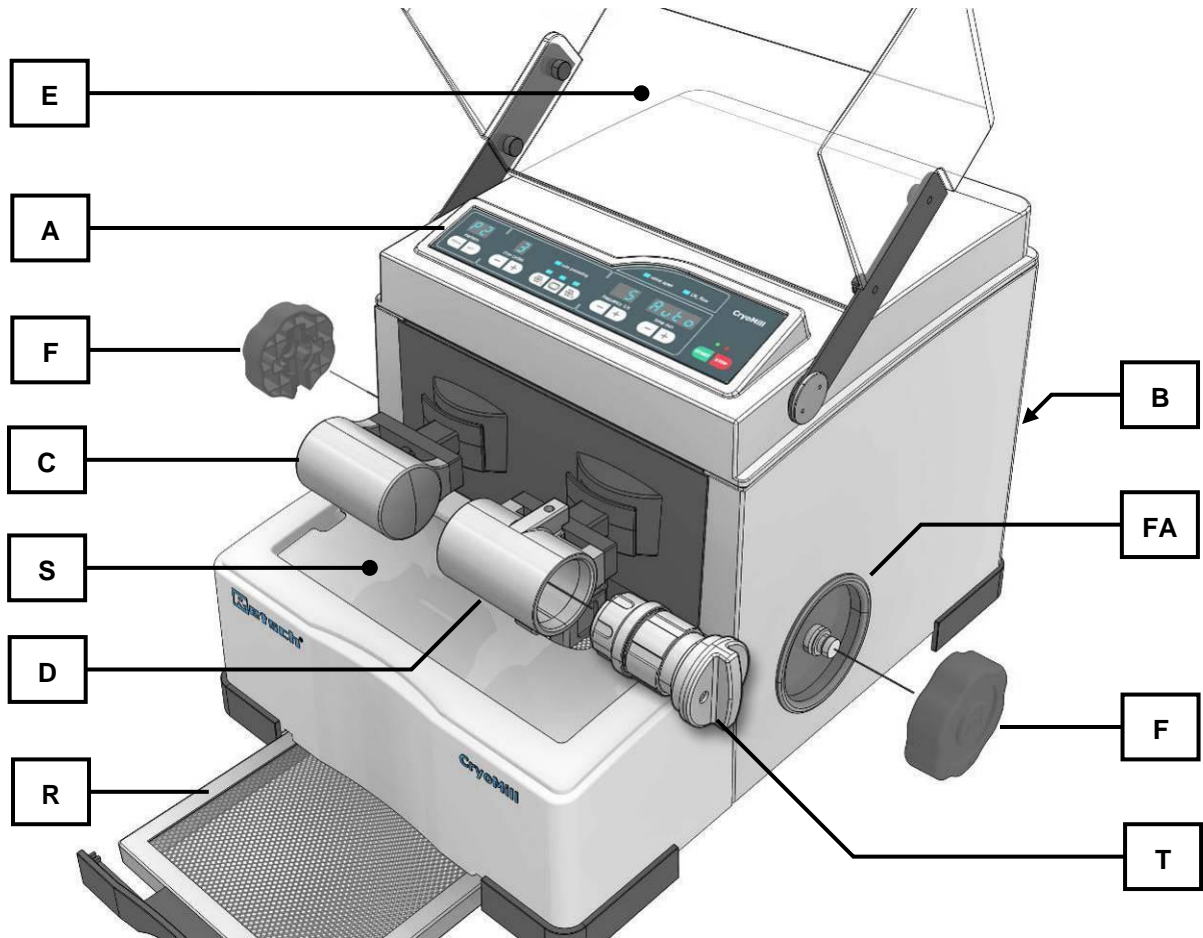

Fig. 17: Front view

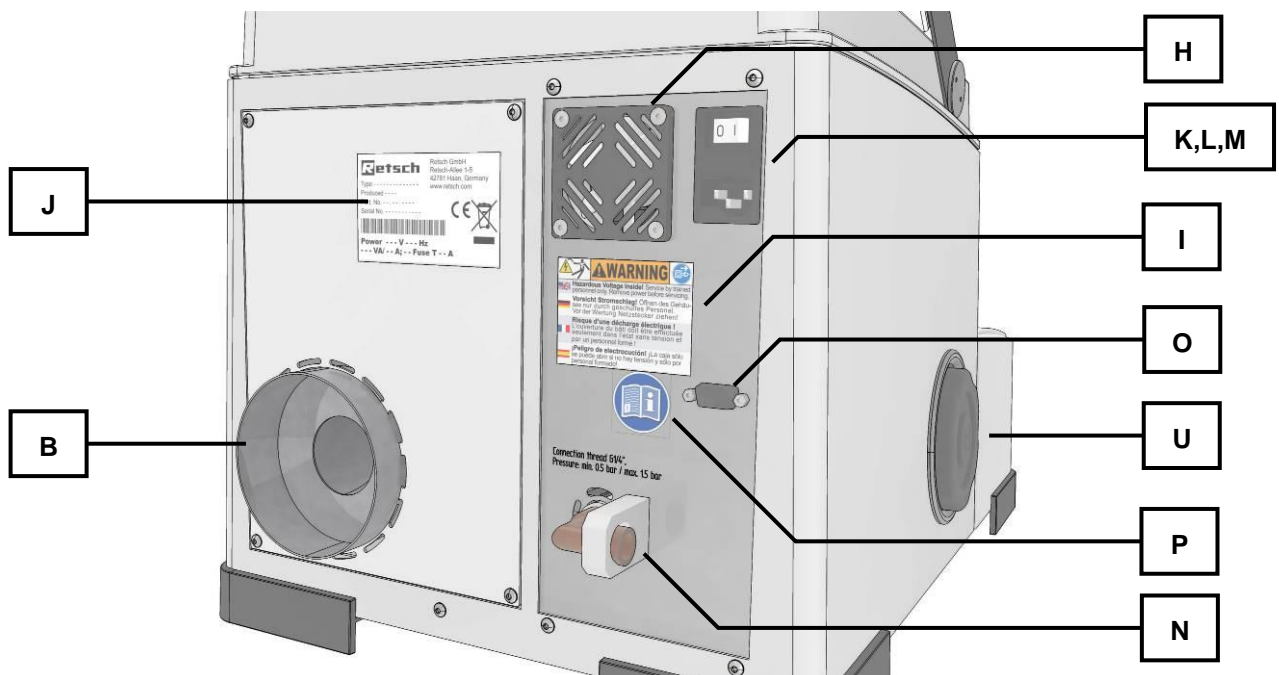

Fig. 18: Rear view

5.3 Summary table of device parts

Element	Description	Function
A	Display and control unit: See below for explanations	Time preselection, frequency preselection and starting/stopping the machine
B	Nitrogen gas outlet	Outlet for gaseous nitrogen
C	Counterweight left	Counterweight for the cooling jacket with grinding jar
D	Cooling jacket	Forms the cooling system together with the grinding jar (T)
E	Hood	Closes the grinding chamber
F	Opening aid	Can be mounted on the grinding jar cover for simple removal of the grinding jar
FA	Support for opening aid	Storage of the opening aid
H	Fan	Ventilates the motor and the interior of the mill
I	Caution remove mains plug sign	Safety instruction
J	Type plate	Information about the device and connected loads
K	ON / OFF switch	Switches the device on and off
L	Fuse drawer	Accommodates two glass fuses
M	Connector	Connector for the mains lead of the device
N	Cooling agent connection	Connection for liquid nitrogen
O	RS232 interface	Enables updating of the operating software
P	Observe operating instructions sign	Safety instruction
R	Condensation collecting filter	Collects the condensation from the cooling system and allows it to evaporate
S	Drip tray	Housing protection
T	Grinding jar	Forms the cooling system together with the cooling jacket (D)

5.4 Operating Controls, Displays and Functions

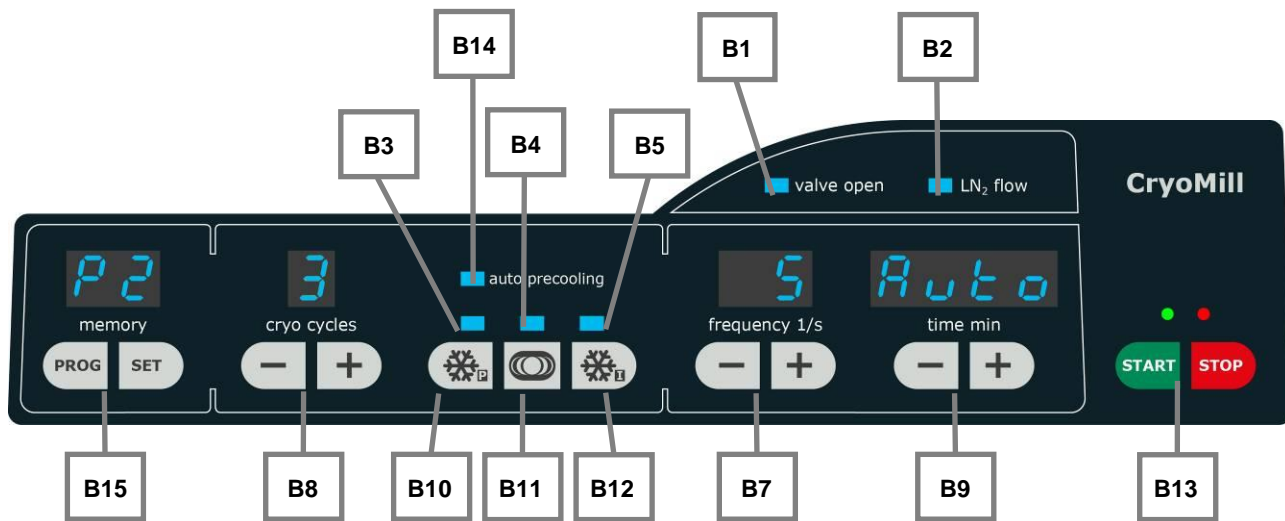

Fig. 19: Control unit

Element	Description	Function
B1	LED on – valve open	Indicates whether the internal solenoid valve on the liquid nitrogen supply line is open or closed.
	LED off – valve closed	
B2	LED on – liquid nitrogen is flowing	Indicates that liquid nitrogen is flowing into the device.
	LED off – no liquid nitrogen	
B3	LED precooling is running (Vkz)	Precooling is taking place / lights up when values are set
B4	LED grinding is running (Mz)	The sample is ground / lights up when values are set
B5	LED intermediate cooling is running (Zkz)	Intermediate cooling is taking place / lights up when values are set
B7	Frequency minus button	In setting mode and in operating mode: reduces the set frequency by 1 Hz (1/s). Continuous pressing switches on fast scrolling of numbers.
	Frequency plus button	In setting mode and in operating mode: increases the set frequency by 1 Hz (1/s). Continuous pressing switches on fast scrolling of numbers.
B8	Cooling cycle minus button	Reduces the number of total cycles by 1
	Cooling cycle plus button	Increases the number of total cycles by 1
B9	Time minus button	In setting mode and in operating mode: Reducing the set <ul style="list-style-type: none"> • Precooling • Grinding time • Intermediate cooling time
	Time plus button	In setting mode and in operating mode: Increasing the set <ul style="list-style-type: none"> • Precooling • Grinding time • Intermediate cooling time
B10	Setting precooling	Preselection button to set the precooling / switching automatic precooling on or off)
B11	Setting grinding	Preselection button to set the grinding time
B12	Setting intermediate cooling	Preselection button to set the intermediate cooling time
B13	Start button Green LED	Starts grinding operation Indicates grinding operation
	Stop button Red LED and ON	Interrupts or ends grinding operation, places the machine in stand-by mode
B14	LED - auto precooling	Indicates whether the automatic precooling is switched on
B15	PROG button	Button to select a program
	SET button	Button starts / saves a program editing

5.5 Inserting the Grinding Jar

 **CAUTION**

Burn-like injuries or frostbite

Escaping of liquid nitrogen

- Liquid nitrogen has a temperature of -196 °C and can cause burn-like injuries or frostbite in the event of skin or eye contact.
- **Never switch the machine on without firmly closed cooling jacket.**
- **Never switch the machine on if a sealing ring (grinding jar, grinding jar support, cooling jacket) has not been correctly inserted or is damaged.**

 **CAUTION**

Crushed or bruised fingers

Falling grinding chamber protective hood

- The protective hood of the grinding chamber can cause crushed or bruised fingers if it falls down.
- **Hold the flap tight when closing.**

5.5.1 Inserting and removing CryoMill special grinding jar

 **CAUTION**

Clogged piping

Formation of ice

- Ice or foreign matter can clog the pipe and subsequently cause malfunctioning.

Keep the cooling system and the supply pipe dry and free of foreign matter.

- **Do not insert the grinding jar if it is damp or covered with frost.**
- **Use the cooling jacket sealing plug (KA) if you are not going to use the device for a long time.**
- **Do not let the device run without supervision.**

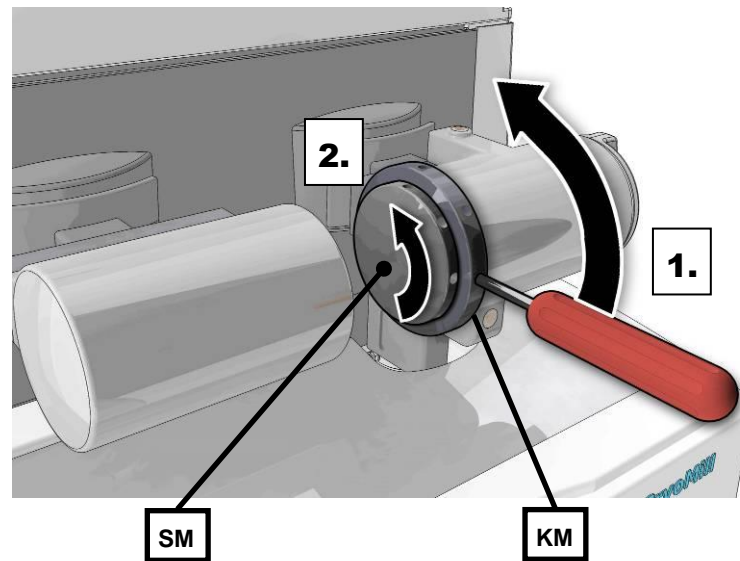

Fig. 20: Releasing the grinding jar safety device

- Loosen the lock nut (KM) with the locking pin
- Loosen the screw (SM) with the locking pin

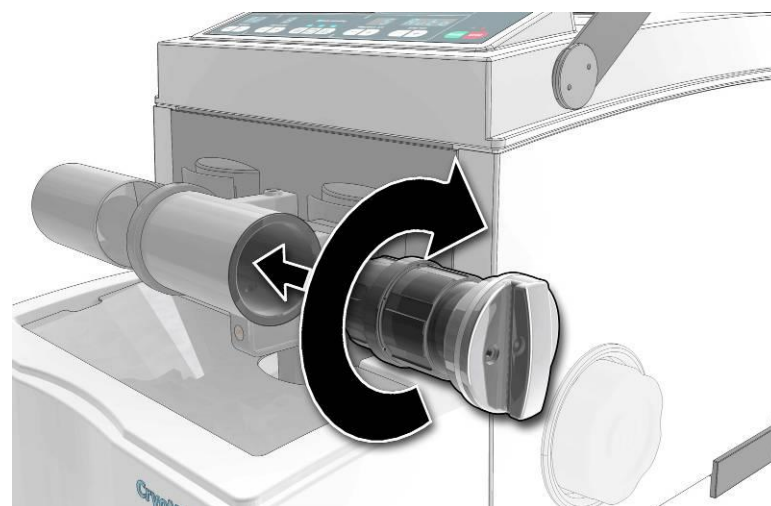

Fig. 21: Inserting the grinding jar

- Make sure that the sealing rings (grinding jar, grinding jar support, cooling jacket) have been correctly inserted and are undamaged.
- Slide the special grinding jar filled with grinding material and the grinding balls into the cooling jacket .
- Completely screw the grinding jar in.

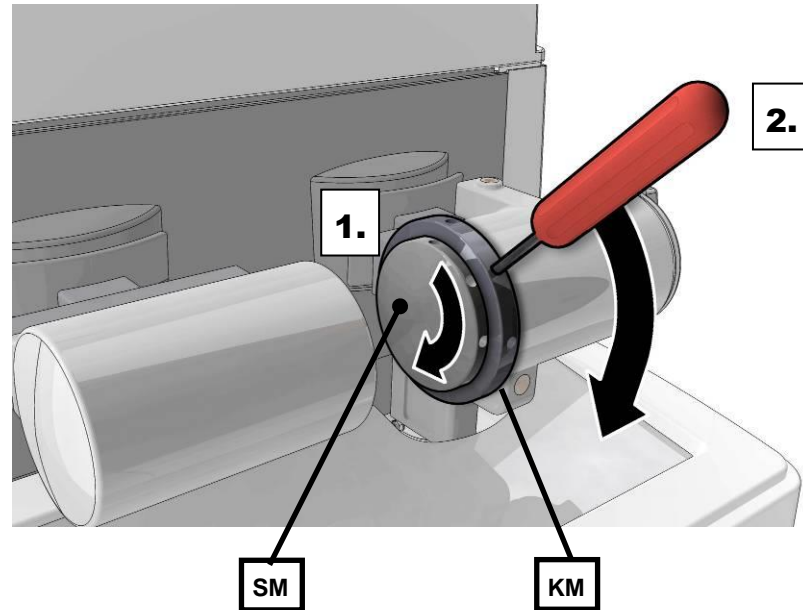

Fig. 22: Securing the grinding jar

- First tighten the screw (SM) with the locking pin.
- Then tighten the lock nut (KM) firmly against the cooling jacket with the locking pin

Take care that the sealing rings (grinding jar, grinding jar support, cooling jacket) are correctly inserted and undamaged and that the grinding jar is screwed tightly to the cooling jacket, as liquid nitrogen may otherwise escape.

The counter screw (SM) must be firmly tightened and secured using the lock nut to prevent any sample material escaping from the grinding jar.

 **CAUTION**

Risk of injury to eyes and skin

The cooling jacket and grinding jar reach very low temperatures during grinding.

- Risk of injuries to eyes and skin caused by severe frostbite
- **Always use goggles and wear protective gloves when opening the cooling jacket and the grinding jar.**



Use the opening aid (F) kept at the side of the device to remove the grinding jar.

- Unscrew the lock nut (KM)
- Unscrew the screw (SM)
- Place the opening aid (F) onto the grinding jar and open it.

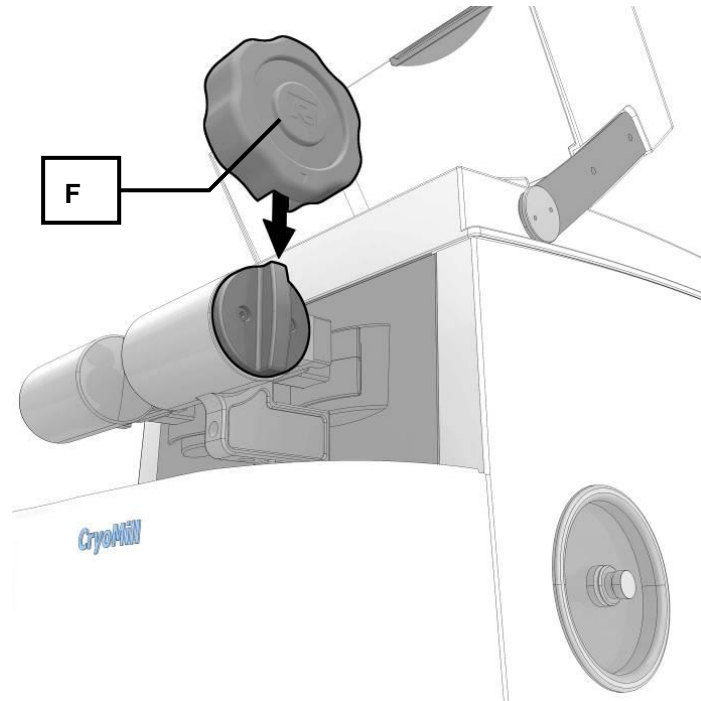

Fig. 23: Using the opening aid

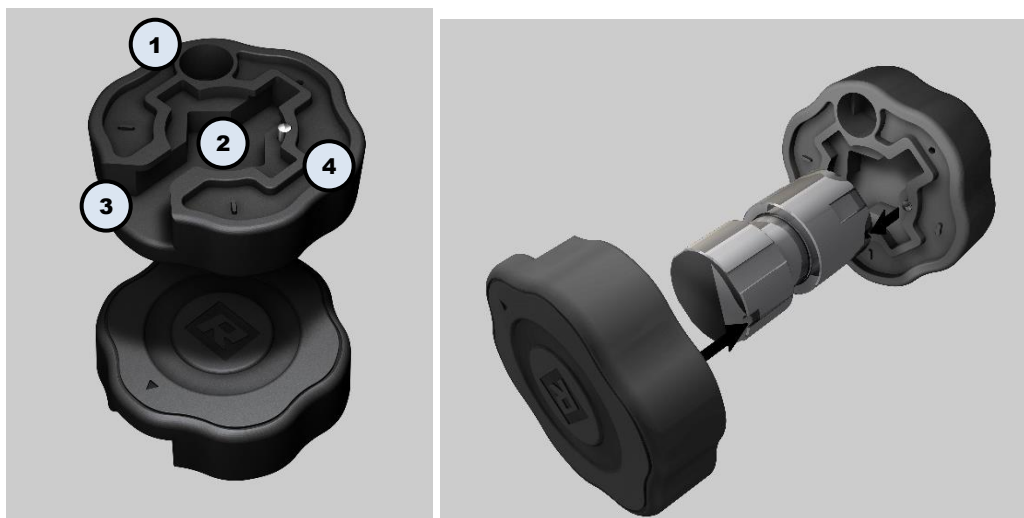

Fig. 24: Opening aids

The grinding jars listed below can be opened with the correspondingly marked shapes of the opening aid:

No.	
1	5 ml steel grinding jar for the adapter
2	Standard grinding jars. Round recess for 35 ml and 50 ml grinding jars, square recess for 10 ml and 25 ml grinding jars.
3	Recess for attaching it to the grinding jar lid (valid for all sizes). Use position 2 of the opening aid in order to lock the opposite side of the grinding jar.
4	Adapter for 2 ml stainless steel reaction vials. Adapter for 2 ml safe-lock reaction vials. Adapter for 5 ml steel grinding jars.

NOTE

H0017

Damage to the PTFE grinding jar

- The threading on the grinding jar can become damaged.
- **When it is being inserted into the device, the PTFE grinding jar must be at room temperature and must not be pre-cooled.**

5.5.2 Inserting the cooling jacket sealing plug

NOTICE

Blocked pipe

Ice formation

- Ice or impurities can block pipes and thereby cause malfunctions.
- **Insert the cooling jacket seal (KA) as soon as you are no longer using the device.**

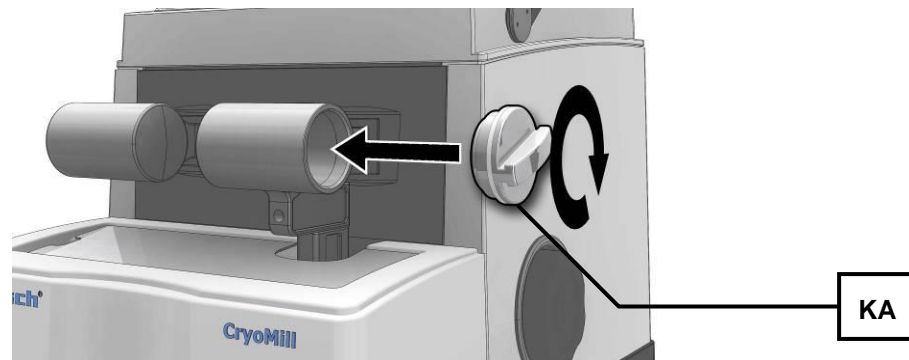

Fig. 25: Inserting the cooling jacket seal

5.5.3 Insert the adapter for 4/2 x 5 ml grinding jar

You can operate the CryoMill with 4 or 2 grinding jars (5 ml).

- Ensure that the sealing rings (grinding jar, grinding jar support, cooling jacket) have been correctly inserted and are undamaged.
- Insert the 5 ml grinding jars into the adapter as illustrated below.

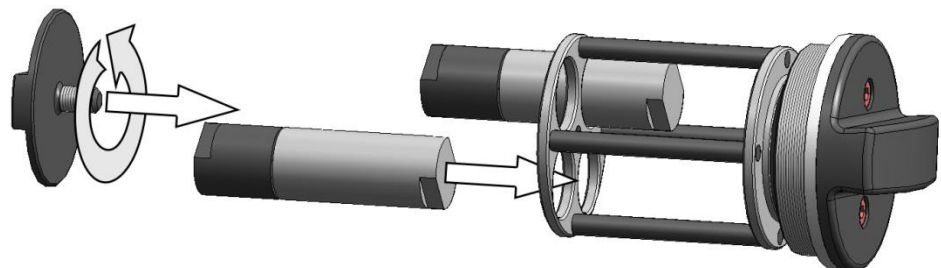

Fig. 26: Inserting the 5ml grinding jars

Note the positioning of the grinding jars. If you are using two grinding jars, these must be inserted in opposite openings.

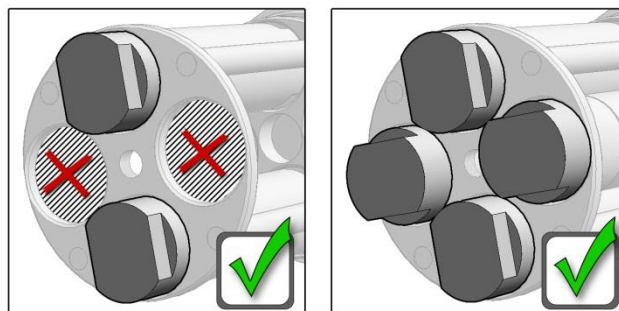

Fig. 27: Position of 5ml grinding jars

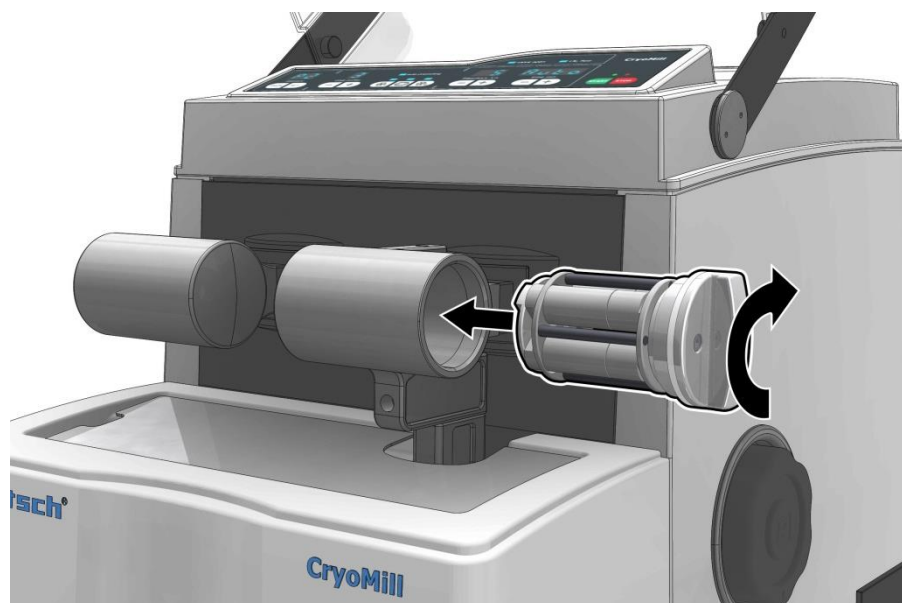

Fig. 28: Inserting the grinding jar adapter

5.5.4 Insert the adapter for 6 / 4 / 2 x 2-ml Eppendorf reaction vial

NOTICE

Breaking of Eppendorf reaction vials

Changing material properties

- The Eppendorf reaction vials that are available as accessories change their material properties during the cryogen grinding.
- **Do not reuse reaction vials after the cryogen grinding.**
- **Do not insert reaction vials in centrifuges after the cryogen grinding**
- **Grinding may take place with a maximum 25Hz.**

You can operate the CryoMill with 2, 4 or 6 Eppendorf reaction vials (2ml).

NOTICE

Grinding with Eppendorf reaction vials may only be conducted at a maximum of 25Hz (frequency 1/s).

- Ensure that the sealing rings (grinding jar, grinding jar support, cooling jacket) have been correctly inserted and are undamaged.
- Insert the 2ml Eppendorf reaction vials into the adapter for reaction vials as illustrated below.

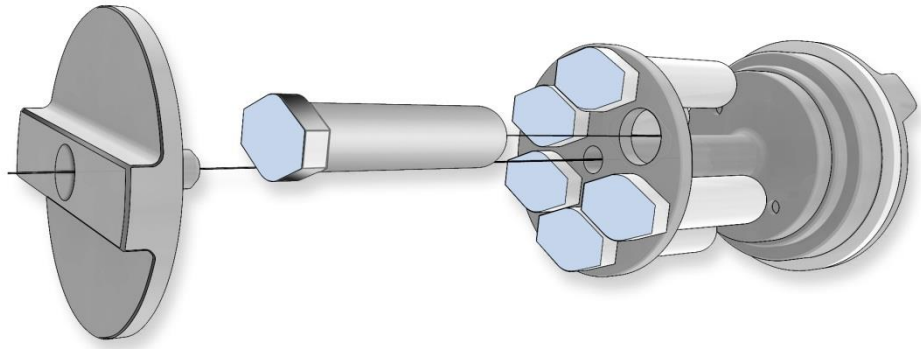

Fig. 29: Inserting 2ml Eppendorf reaction vials

Note the positioning of the Eppendorf reaction vials. If using two or four reaction vials, these must be inserted in opposite openings.

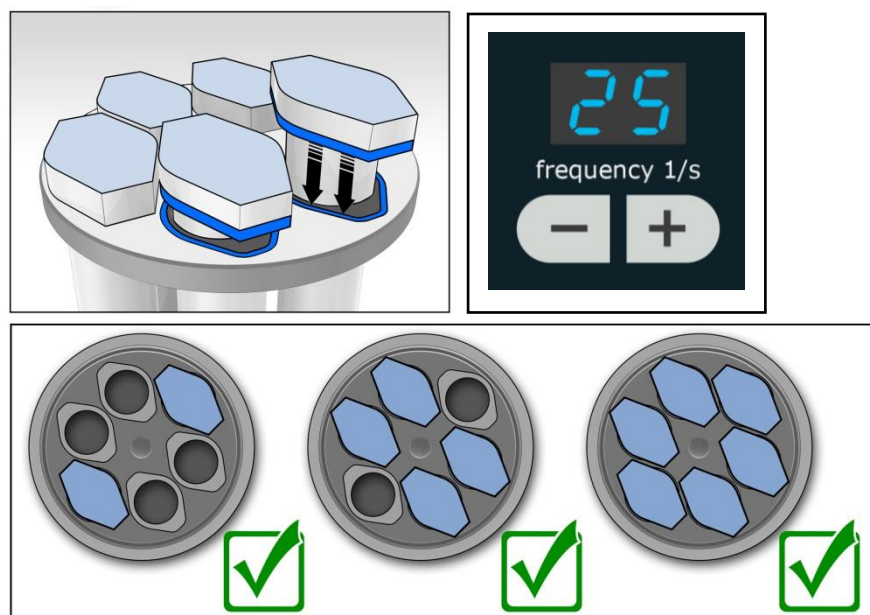

Fig. 30: Position of 2 ml reaction vials

5.6 Explanations of the grinding cycles

You can deploy the CryoMill for grinding with cooling or grinding without cooling.

5.6.1 Grinding without cooling

- Switch the CryoMill on at the main switch.
- Set the cryo cycles to - .



- Set the desired grinding time (B9)+(B11).
- Press the START button.

The START LED lights up. The remaining grinding time and the set frequency are displayed.

5.6.2 Grinding with cooling

The following program points can be set when grinding with cooling.

- precooling (Vkz)
- grinding time (Mz)
- intermediate cooling time (Zkz)
- cryo cycles (Number of cooling/grinding cycles)
- frequency 1/s (Grinding frequency)

A single grinding cycle consists of the precooling and the set grinding time. The intermediate cooling time does not apply in the case of a single grinding cycle.

$$Vkz + Mz = \text{total grinding time}$$

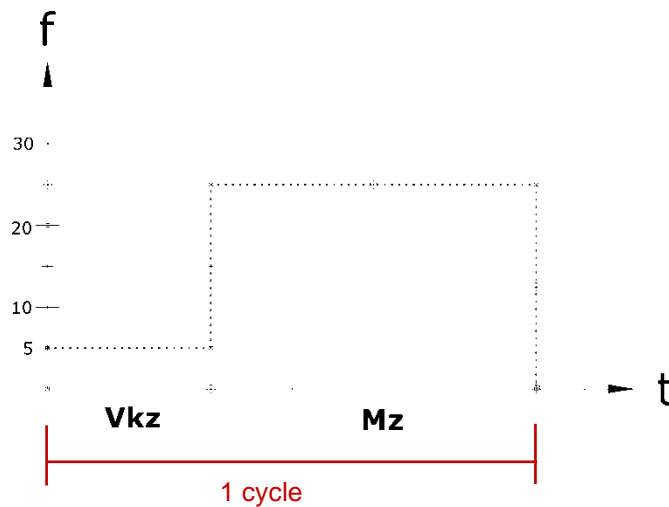

Fig. 31: Sequence of a single grinding cycle

The first grinding cycle consists of the pre-cooling and the set grinding time. All other grinding cycles consist of the intermediate cooling time and the set grinding time.

Number of cryo cycles: n

$$t_n = (Vkz + Mz) + [(n - 1)(Zkz + Mz)]$$

t_n = total grinding time

Vkz = precooling time

Mz = grinding time

Zkz = intermediate cooling time

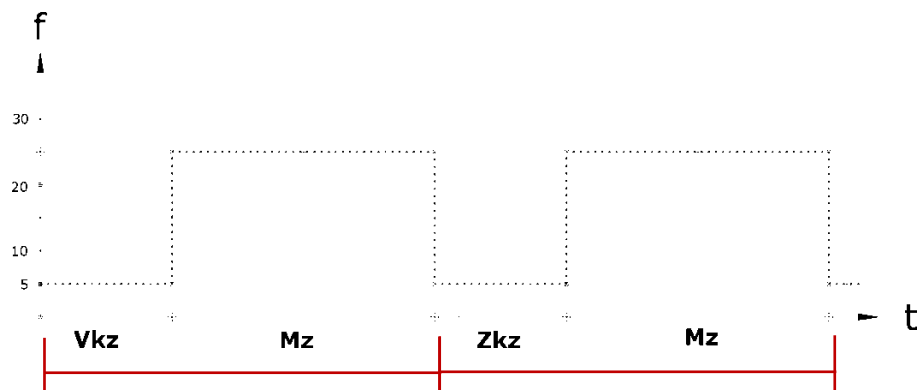

1. cycle

2. cycle

Fig. 32: Sequence of two grinding cycles

5.7 Programme Mode

5.7.1 Grinding without program

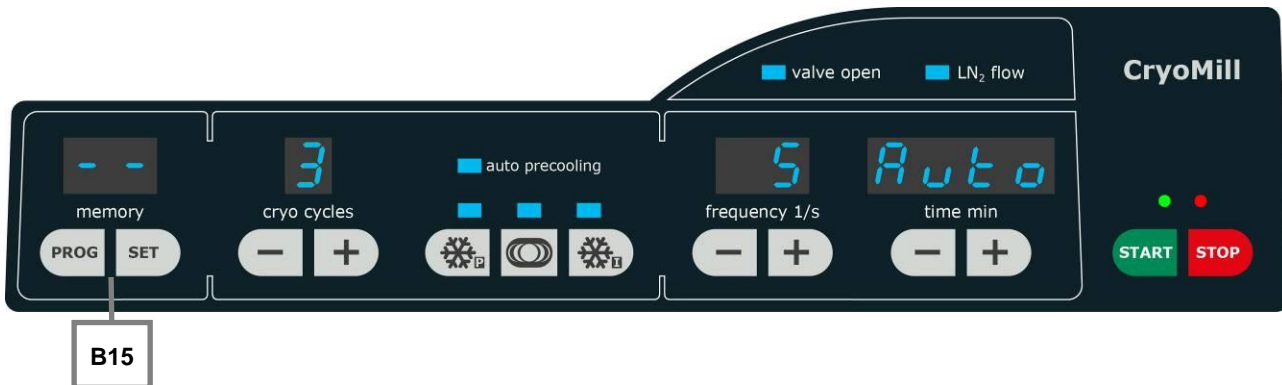

Fig. 33: Grinding without program

- Press the PROG button (**B15**) until “- -” is shown in the **memory** display .
The display advances one program each time the button is pressed
-- > P1 > P2 > P3 > P4 > P5 > P6 > P7 > P8 > P9
- The SET button (**B15**) is blocked in the “- -” mode

5.7.2 Grinding with program

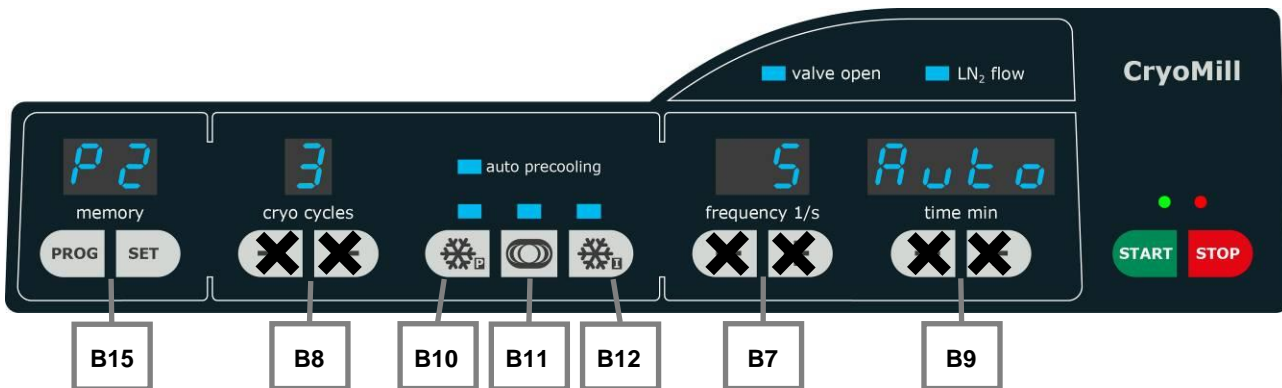

Fig. 34: Grinding with program

5.7.2.1 Selection of a program

- Press the PROG button (**B15**) until the required program is shown in the **memory** display.
- The display advances one program each time the button is pressed .
-- > P1 > P2 > P3 > P4 > P5 > P6 > P7 > P8 > P9
- The buttons **B8**, **B7**, **B9** are blocked due to the selection of a program.

5.7.2.2 Display of the program grinding parameters

Precooling

- Press the precooling button (**B10**).
- The set time for precooling appears in the **time min** (**B9**) display.

Grinding time

- Press the grinding time button (**B11**).
- The set time for the grinding time appears in the **time min** (**B9**) display.

Intermediate cooling

- Press the intermediate cooling button (**B12**).
- The set time for the intermediate cooling appears in the **time min (B9)** display.

5.7.2.3 Create/change a program

- Press the PROG button (**B15**) until the required program (memory space) is displayed in the **memory** display.
- Press the SET button (**B15**).
- All displays and the corresponding LEDs for which settings are possible light up or flash.
- Set the parameters for grinding as described in the following chapters:
 - Number of grinding cycles
 - Precooling
 - Grinding time
 - Intermediate cooling time
 - Grinding frequency
- It is possible to cancel at any time using the PROG button (**B15**)

- Press the SET button (**B15**).
- Pressing the SET BUTTON (**B15**) again stores all parameters in the program.

5.7.2.4 Delete program

- Press the PROG button (**B15**) until the program to be deleted is displayed in the **memory** display.
- Press the shortcut SET (**B15**) and - (**B8**) for at least 5 seconds.

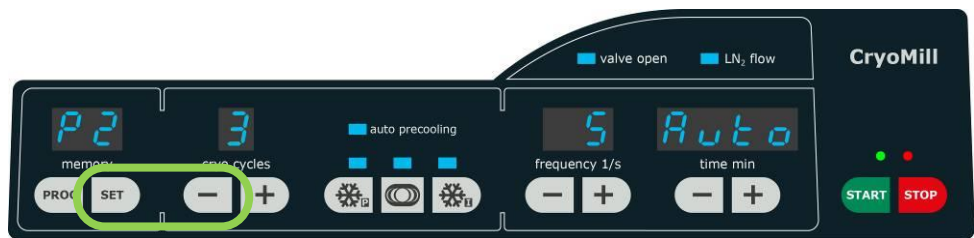

Fig. 35: Deleting a program

- The program is deleted and the parameters are assigned with the values “0” or “-”.
- It is not possible to start a deleted program.

5.8 Setting grinding cycles



Fig. 36: Setting the grinding cycles

- Switch the CryoMill on at the main switch.
- After switching on, the last used grinding parameters are displayed and can be used.
- You can set 0 (“-”) to 9 grinding cycles

NOTICE

If 0 (“-”) CryoCycles are set, the grinding is conducted without nitrogen. In this case the buttons **B10**, **B11** and **B12** are blocked.

- The first cycle consists of the precooling phase and grinding time

- Cycles 2 to 9 each comprise an intermediate cooling and grinding.
- Press the respective buttons (B8) to set the grinding cycles.
- **+** Pressing briefly increases the number.
- **-** Pressing briefly reduces the number.
- The display runs more quickly when pressed longer.

5.9 Setting the precooling time

NOTICE

The machine runs at a fixed frequency of 5 Hz during the precooling and intermediate cooling. A range of from 30 seconds to 99 minutes can be set for precooling.

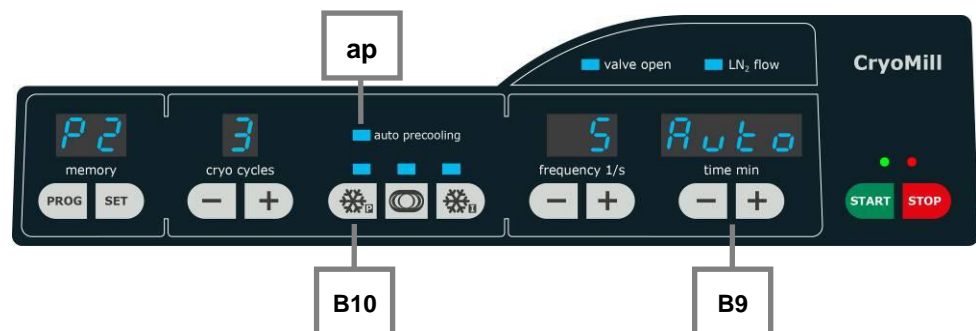

Fig. 37: Setting precooling

After switching on, the last used grinding parameters are displayed and can be used.

- Switch the CryoMill on at the main switch.
 - Press the button (**B10**) to set precooling
 - The precooling LED lights up.

You can choose between two precooling versions:

5.9.1 Precooling with definable precooling time

- Use the buttons (**B9**) to set precooling.
- **+** Pressing briefly increases the duration.
- **-** Pressing briefly shortens the duration.

The display runs more quickly when pressed longer.

5.9.2 Automatic precooling

In the case of automatic precooling the grinding only starts once the entire system has been sufficiently cooled. This is checked by a sensor (see chapter >>Connecting the cooling agent supply <<)

Switch automatic precooling on

- Press the button (**B10**) for at least 2 seconds.
- The auto precooling (**ap**) LED is lit up.
- “Auto” is shown in the **time min** display.

Switch automatic precooling off

- Press the button (**B10**) for at least 2 seconds.
- The auto precooling (**ap**) LED is extinguished.
- “08:00” is shown in the **time min** display.

5.10 Setting the grinding time

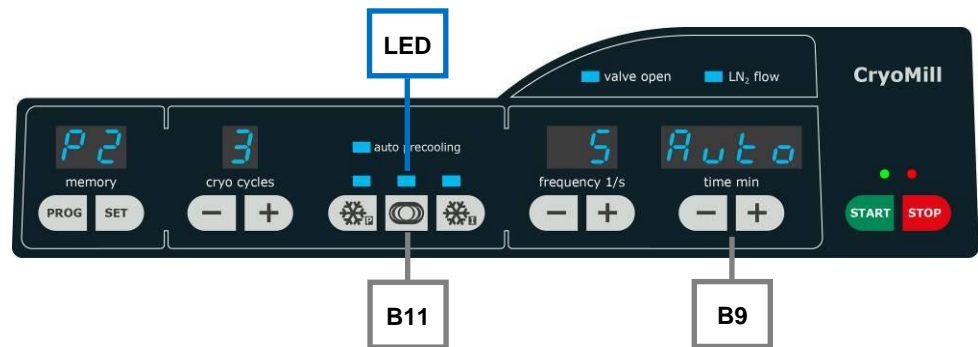

Fig. 38: Setting the grinding time

- Press the button (B11) to set the grinding time. The grinding time LED lights up.
- Use the buttons (B9) to set the grinding time
 - + Pressing briefly increases the duration.
 - Pressing briefly shortens the duration. The display runs more quickly when pressed longer.

NOTICE

In the case of grinding without cooling, the grinding time can be set directly using the buttons (B9).

5.11 Setting the duration of intermediate cooling

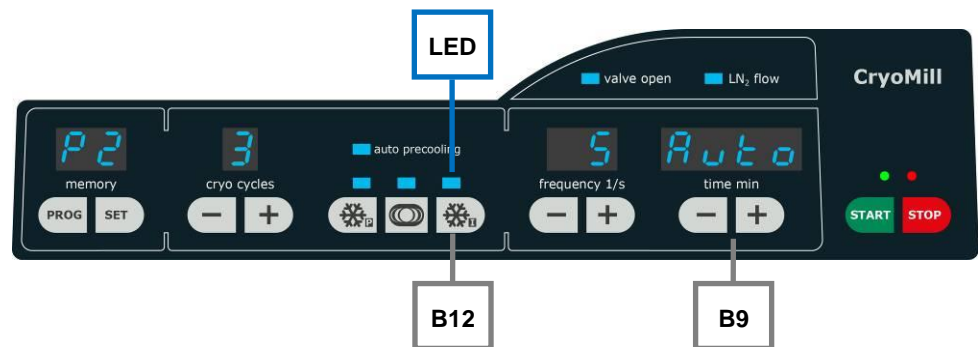

Fig. 39: Setting the intermediate cooling

- Press the button (B12) to set the intermediate cooling . The intermediate cooling time LED lights up.
- Use the buttons (B9) to set the intermediate cooling time (30 seconds to 99:00 minutes).
 - + Pressing briefly increases the duration.
 - Pressing briefly shortens the duration. The display runs more quickly when pressed longer.

5.12 Setting the grinding frequency

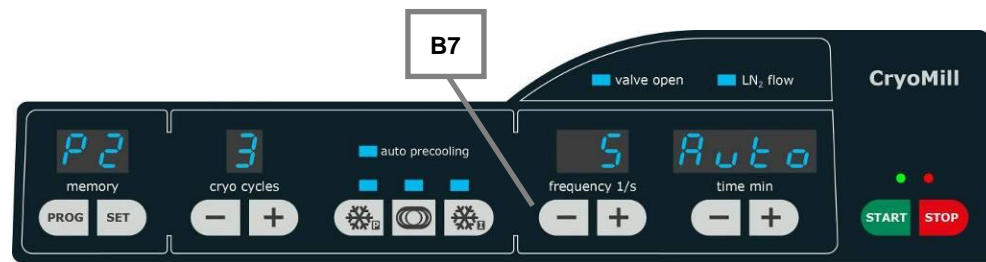

Fig. 40: Frequency 1/s

- Switch the CryoMill on at the main switch.
It is only possible to adjust the grinding frequency if the button (B11) for setting the grinding parameters has been pressed and the LED (B11) is lit up.

- Press the button (B11).
- Press the respective buttons (B7) to set the grinding frequency .
The selectable frequency range is from 5 to 30 Hz in steps of 1 Hz.

- **+** Pressing briefly increases the frequency.

- **-** Pressing briefly reduces the frequency.

The display runs more quickly when pressed longer.

The frequency of precooling and intermediate cooling is fixed at 5 Hz. The frequency cannot be adjusted while setting the precooling or intermediate cooling time.

5.13 Starting the grinding process



CAUTION

Burn-like injuries or frostbite

Escaping of liquid nitrogen

- Liquid nitrogen has a temperature of -196 °C and can cause burn-like injuries or frostbite in the event of skin or eye contact.
- **Never switch the machine on without firmly closed cooling jacket.**
- **Never switch the machine on if a sealing ring (grinding jar, grinding jar support, cooling jacket) has not been correctly inserted or is damaged.**

NOTICE

The grinding process can only be started if the hood is closed.



Fig. 41: Starting the grinding process

- Press the START button to start the grinding process.
- The Start LED (green) lights up. At the same time the solenoid valve opens and liquid nitrogen can flow into the cooling system.

5.14 Interrupting and continuing the grinding process

5.14.1 Pausing grinding

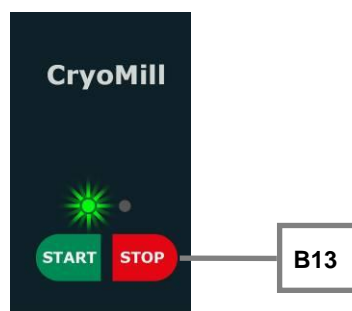

Fig. 42: Pausing grinding

- Press the STOP button (**B13**) once.
- Grinding is interrupted and the LED above the START button flashes.

5.14.2 Cancelling grinding

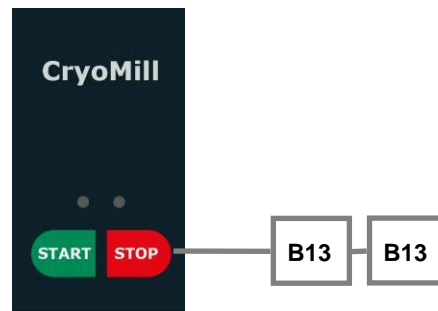

Fig. 43:

- Press the STOP button (**B13**) twice.
- The grinding is ended and the two LEDs above the START and STOP buttons are off.

5.15 Stopping the grinding process



Fig. 44: Ending the grinding process

- Press the STOP button to end the grinding process.
- The STOP LED (red) lights up. At the same time the solenoid valve closes.

In the event that the supply of liquid nitrogen has been interrupted during operation, this is indicated by the flashing of the remaining time LED (**B6**) at the end of the grinding time. Pressing once interrupts the grinding process, for example to appraise the grinding sample. The remaining grinding time is still visible on the display.

By pressing the start button again, the mill continues running until the grinding time has completely expired.

Pressing the stop button twice aborts the grinding process. The machine is now in start mode. By pressing the start button, the display is activated again and the grinding time is reset to the last start setting.

The duration can be changed during the grinding process. The grinding process is automatically ended on expiry of the grinding time. The display is reset to the last value started.

NOTICE If the milling process is aborted due to too little liquid nitrogen in the cooling circuit, the error E85 is displayed and the LED on top of the STOP button flashes. The error can be acknowledged by pressing the STOP button. The LEDs on top of the START and STOP buttons are alternately flashing and the remaining process time is displayed.

- To continue the grinding process (to do so enough liquid nitrogen must be present again), press the START button.
- To abort the grinding process and to display the original parameters again, press the STOP button once again.

An exception is the interruption during the automatic precooling stage (first cooling stage), before the process time (3 min) is counted down. As to this point in time, no process time is displayed, the time display (remaining process time) remains off in case of error E85.

5.16 Operating hours display

- Switch the device off at the mains switch.

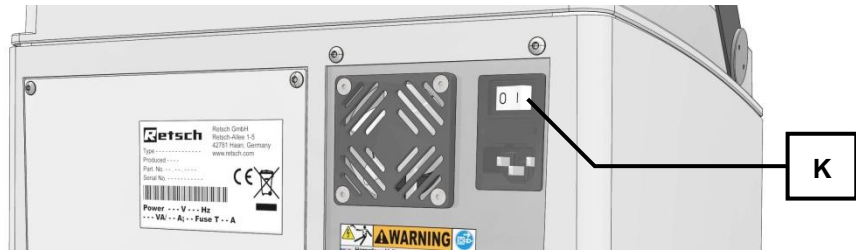

Fig. 45: Switching the device on and off

- Keep the buttons cryo cycles (**B8**) + and frequency (**B7**) - pressed simultaneously and with the buttons pressed, switch the device on at the mains switch.

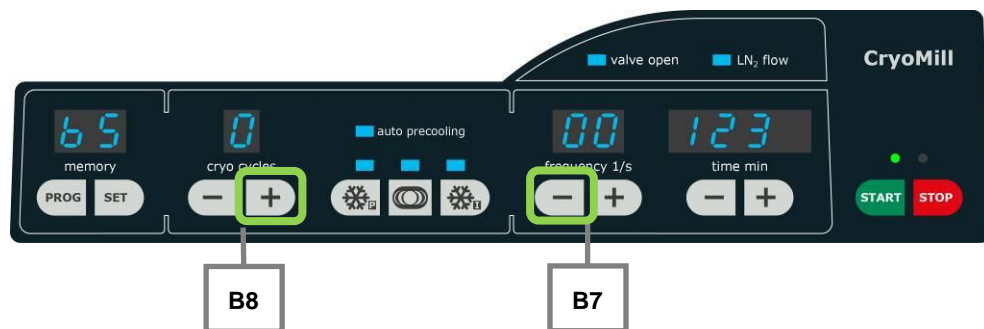

Fig. 46: Display of the operating hours

The total operating time in hours is displayed. The maximum value that can be depicted is 999999 hours. The letters bS are displayed in the first two places.

Examples:

bS0 00 012 = 12 hours operating time

bS1 23 456 = 123456 hours operating time

- Press the STOP button to exit the operating hours display

5.17 Operating software display

- Switch the device off at the mains switch.

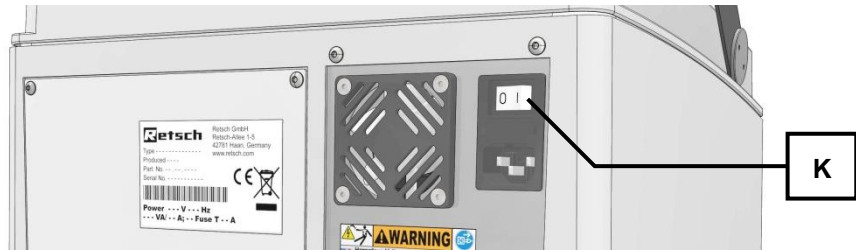

Fig. 47: Switching the device on and off

- Keep the buttons cryo cycles (**B8**) + and frequency (**B7**) + pressed simultaneously and...
- ...with the buttons pressed, switch on the device at the mains switch.

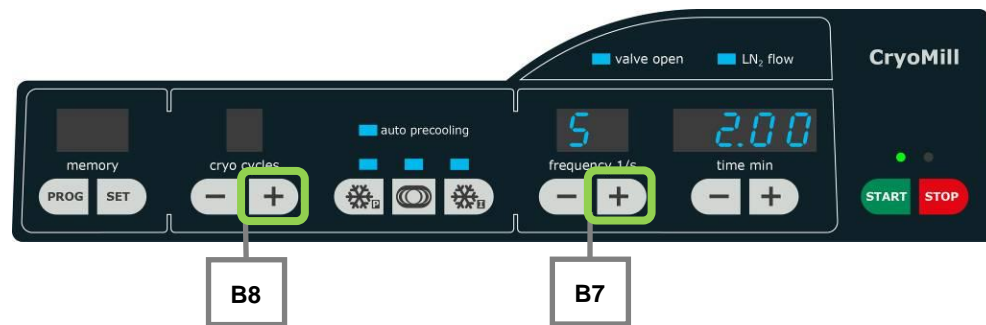

Fig. 48: Display of the software version

The current version of the operating software is displayed across the two right-hand display windows. The letter S is shown in first place.

Examples:

S 1.23 = Version 1.23 of the operating software

S 2.00 = Version 2.00 of the operating software

- Press the STOP button to exit the display of the operating software.

5.18 Replacing the machine fuses

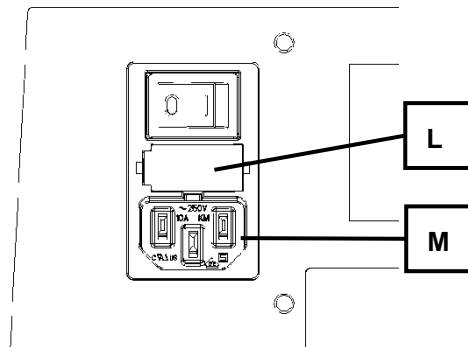

Fig. 49: Replacing the device fuses

The following glass fuses are needed for the CryoMill:

2 T4A

- Pull the mains plug from the connector (**M**).
 - Press in the catch at the side. This releases the fuse holder (**L**) so that it can be pulled out.
 - Replace the fuses.
 - Push the fuse holder (**L**) in until it engages.

6 Working instructions

6.1 General

The CryoMill is an extremely modern, efficient product from Retsch GmbH.

Due to the large selection of accessories, the CryoMill has a wide range of potential applications in industrial and research laboratories.

It is primarily deployed in the chemical and pharmaceutical area, in mineralogy and biology etc.

 **CAUTION**

2.V0004

Risk of explosion or fire

Changing sample properties

- Consider that the properties and therefore also the hazardousness of your sample can change during the grinding process.
- **Do not use any substances in this device which carry the risk of explosion or fire.**

 **CAUTION****Danger of personal injury**

Dangerous nature of the sample

- Depending on the dangerous nature of your sample, take the necessary measures to rule out any danger to persons.
- **Observe the safety guidelines and datasheets of your sample material.**



6.2 The grinding process

- Insert your grinding jar filled with grinding sample and grinding ball/s into the grinding jar support as described in the chapter "Inserting the grinding jar".
- Close the hood.
- Set the grinding parameters.
- Open your external liquid nitrogen supply line.
- Start the device.

Do not open the hood during the grinding process.

The grinding jars are brought to a halt immediately by the built-in brake, however the grinding process can no longer be continued with the remaining grinding time.

The device must be restarted. The original parameters are available here.

6.3 Quantities of sample material and feed sizes

In addition to the instrument settings, the filling level of the grinding jar is also of crucial importance for a successful grinding process in the Cryogenic Mixer Mill of Retsch GmbH. **When grinding bulk materials, the grinding jar filling should consist of approximately one third of sample and one third of ball quantity.** The remaining third is the free grinding jar volume, which is required for the movement of the balls.

If an increase or decrease in sample volume is to be expected during the grinding process, the amount of sample can be adjusted within the range listed in the table. Thus, e.g. for voluminous materials such as wool, leaves, grasses and similar, a material filling level of 70 – 80 % is necessary. For wet grinding with grinding balls < 3 mm, the ball charge should be 60 % of the grinding jar volume.

Grinding jar nominal volume [ml]	Sample quantity [ml]	Max. feed size [mm]	Recommended ball filling (unit)						
			Ø5 mm	Ø7 mm	Ø10 mm	Ø12 mm	Ø15 mm	Ø20 mm	Ø25 mm
1.5	0.2 – 0.5	1	1 – 2						
5.0	0.5 – 2.0	2		1 – 2	-	-	-	-	-
10.0	2.0 – 4.0	4		5 – 7	1 – 2	1 – 2		-	-
25.0	4.0 – 10.0	6			5 – 6	2 – 4	1 – 2	-	-
35.0	6.0 – 15.0	6			6 – 9	4 – 6	2 – 3	1	
50.0	8.0 – 20.0	8			12 – 14	6 – 8	3 – 4	1	1

Safe-Lock reaction vessel	Sample quantity	Max. feed size	Recommended ball filling (unit)	
			Ø3 mm	Ø5 mm
1.5 ml	0.5 ml	1 mm	10 - 12	2 - 3
2 ml	0.7 ml	1.2 mm	14 - 16	3 - 4

6.4 Working instructions

The grinding jar and its content are cooled by means of liquid nitrogen (LN2) until it is possible to grind soft materials such as rubber.

Precooling is required until the ideal grinding temperature is reached. The drive operates at a lower frequency (5Hz) here to prevent the moving parts of the device from freezing. The fan is switched on during precooling and blows the air heated by the motor in the front through the openings of the rocker arms into the grinding chamber. This warm air prevents the rocker arm bearing from cooling down. It is therefore also necessary to allow the fan to run on for a while after switching the grinding off.

In the preliminary tests an average precooling of approx. 10 to 15 minutes was determined.

The grinding time was approx. 4 – 5 minutes.

The valve is switched off when the optimal temperature is reached. Grinding can begin as from this time and the valve will be switched on and off according to the temperature.

Grinding can also take place without cooling, in which case the cryo cycles are set to -.



Manual cooling is started by pressing the shortcut (B10) and (START B13). The valve remains open as long as the buttons are kept pressed.

7 Safety functions and fault display

7.1 Error Messages

rror cod	(FEHLER) BESCHREIBUNG	DEFECT DESCRIPTION TRANSLATION
E10	ANTRIEB ÜBERLASTET	DRIVE OVERLOAD
E21	FEHLER DREHZAHL	FAILURE ROTATION SPEED
E22	FEHLER TASTATUR	FAILURE KEYPAD
E24	FEHLER VENTIL	FAILURE VALVE
E41	FEHLER DREHZAHLSENSOR	FAILURE SPEED SENSOR
E42	FEHLER TEMPERATURSENSOR 1	FAILURE TEMPERATURE SENSOR 1
E43	FEHLER TEMPERATURSENSOR 2	FAILURE TEMPERATURE SENSOR 2
E51	FEHLER SICHERHEITSSCHALTER	SATETY SWITCH DEFECTIVE
E85	KEIN STICKSTOFF	NO LIQUID NITROGEN
E86	LECKAGE	LEAKAGE
H40	MASCHINE SCHLIESSEN	CLOSE MACHINE

8 Cleaning, Wear and Maintenance

8.1 Cleaning

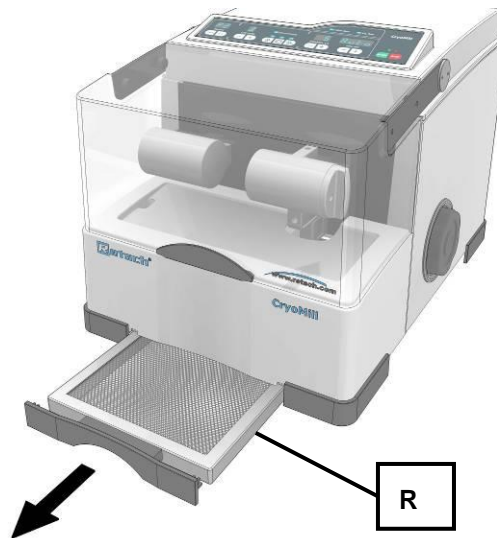

Fig. 50: Pulling out the condensation collecting filter

The condensation collecting filter must be cleaned regularly depending on the ambient conditions, the degree of use and the general air humidity.

- Pull out the condensation collecting filter (R).
 - Clean the condensation collecting filter under running water with a little standard washing up liquid.
 - Allow the collecting filter to dry and then insert in the device again.

8.2 Wear

The grinding tools may become worn, depending on the frequency of the grinding operation and the sample material. The grinding jars and the balls should be regularly checked for wear and replaced if necessary.

8.3 Wearing parts

 **CAUTION**

Personal injury

Incorrect repairs

- This operating manual does not include instructions for repair.
 - **For your own safety repairs should be carried out only by Retsch GmbH or an authorised representative (service technicians).**
-

8.4 Maintenance

The grinding tools may become worn, depending on the frequency of the grinding operation and the sample material. The grinding jars and the balls should be regularly checked for wear and replaced if necessary.

8.5 Checks

Correct functioning of the hood switch must be checked regularly.

- Switch on the machine with switch (K).
- Start grinding operation with START button.
- Lift the hood.

If there is an opening gap of a few cm the machine switches itself off and H40 appears in the display.

- Cancel H40 with the STOP button.



If this switching-off function does not take place the CryoMill must be checked immediately by Retsch-Service.

9 Safety and occupational health instructions

 **CAUTION****Danger of injury to eyes and skin**

Frostbites through liquid nitrogen

- Liquid nitrogen has a temperature of -196 °C and may cause injuries similar to burns on skin or eye contact or cause frostbite.
- **Always use goggles and wear protective gloves when opening the cooling casing and the grinding jar.**

 **CAUTION****Use of liquid nitrogen**

- Retsch GmbH rules out any liability claims that may arise in the use of liquid nitrogen or similar cooling agents.
- **Please observe the safety regulations of the cooling liquid supplier.**



9.1 General

This section summarises the general occupational health and safety guidelines for the handling of liquid nitrogen.

 **CAUTION****Handling liquid nitrogen**

General hazardous situations

- The following hazardous situations may arise in the handling of liquid nitrogen: oxygen deficiency situations, cryogenic burns, danger of explosion, oxygen enrichment
- **All users must be informed about the dangers of working with liquid nitrogen in order to be able to work safely.**

9.2 Safety instructions on the handling of liquid nitrogen

9.3 Oxygen deficiency

The main components of air according to volumes are as follows:

- Oxygen O₂ 21 %
- Nitrogen N₂ 78 %
- Argon Ar 1 %

The gases contained in the atmosphere are not toxic. However, a change in concentration (in particular changes to the oxygen concentration) may have effects on life and burns. It is therefore essential for the air breathed in to contain sufficient oxygen (> 19 %).

Humans cannot detect changes in the composition of air within the time that will actually be necessary because the components are colourless and odourless.

9.3.1 Dangers

A danger of suffocation exists as a result of the normal evaporation of the liquid nitrogen that pushes out the oxygen in the air. An oxygen deficiency is dangerous and can cause death through suffocation. The reaction of the organism to oxygen deficiency will differ greatly depending on the individual. It is not possible to provide precise and generally applicable information on the symptoms of an oxygen deficiency.

Example: under normal conditions (20° C; 1013 mbars) 1 l liquid nitrogen evaporates to produce 680 l nitrogen gas.

9.3.2 Causes

An oxygen deficiency may arise during the following work or in the following conditions:

- Nitrogen as liquid or gas
- Natural evaporation of liquid nitrogen
- Refilling of liquid nitrogen
- Leaks in containers for liquid or gaseous nitrogen
- Defect in the air feed or outlet
- Tipping over of the container

This list is not complete.

9.3.3 Recommendations

In order to prevent the danger of an oxygen deficiency, the following measures must be taken.

The vessel:

- must be kept in a vertical position.
- must be provided with a suitable insulating lid.
 - must be protected from direct sunlight and may not be set up near heat sources.
 - may not be transported in vehicles in filled state.
 - must be protected from impact, knocks and rapid movements.
- Ventilate all installation rooms constantly and appropriately.
 - Wear protective clothing (suitable gloves, goggles or face protection and safety shoes).
- Check the oxygen content of the room constantly.
- Always carry an oxygen metre.
- Only trained personnel may work with liquid nitrogen.

This list is not complete.

9.3.4 General conduct in the case of an accident

In the case of an accident from oxygen deficiency the following regulations should be observed.

- Secure the surrounding area to avoid any subsequent accidents.
- Act quickly.
 - The rescuers must take measures to protect themselves (respiratory protection device).
- Move the injured persons from the hazardous area.
- Observe the company instructions for emergencies.
- Ventilate the rooms affected sufficiently.
- Investigate the cause of the accident.

This list is not complete.

9.4 Cryogenic burns

Liquid nitrogen is very cold (-196° C).

The surfaces of vessels that were in contact in liquid nitrogen (in particular during the filling process) may cause skin burns on contact.

9.4.1 Dangers

Cryogenic liquids may:

- bring about burns to the human body
 - make specific materials (metal and plastic) that are not suitable for low temperatures brittle
- generate strong misting depending on atmospheric humidity

9.4.2 Causes

There are two types of cryogenic burns:

9.4.2.1 Burns through splashes

When handling samples and in general when handling liquid nitrogen, personnel must protect themselves from splashes. They can cause cryogenic burns with serious consequential damage, in particular to eyes and face.

9.4.2.2 Burns through contact

Contact of the skin with cold material causes frostbite or cryogenic burns.
The interior of vessels or the samples may never be touched or held with bare hands.

9.4.3 Recommendations

In order to prevent the danger of burning the following points must be observed:

- Never bring cryogenic liquids in contact with the skin.
 - Never touch the cold non-isolated or iced walls of a vessel.
 - Wear personal protective equipment (suitable gloves, goggles or face protection and safety shoes).
- Keep the vessel upright.
 - Use suitable material (e.g. metal hose or PTFE hose) to refill.
- Train personnel.

This list is not complete.

9.4.4 General rules of conduct for splashes with liquid nitrogen

9.4.4.1 To the eyes

- Rinse eyes with much water for 15 min.
- Follow the company instructions for emergencies.
- Consult a doctor

9.4.4.2 On the skin

- Do not rub.
- If possible remove or loosen clothing.
- Slowly and gradually warm the parts affected.
- Do not apply anything to the burnt area.
- Follow the company instructions for emergencies.
- Consult a doctor.

Both lists are not complete.

9.5 Danger of explosion

9.5.1 Dangers

The evaporation of liquid nitrogen may lead to an overpressure in the vessel.

9.5.2 Causes

An increase in the vessel may be attributable to:

- incorrect set-up (use of a closable lid)
- icing on the neck and on the insulating lid

This list is not complete.

9.5.3 Recommendations

To avoid the danger of explosion:

- Always use suitable insulating lids (pay attention to waste gas opening).
- Observe filling levels to avoid the formation of ice on the insulating lid.
- Set up the vessel in dry and roofed rooms.
- Monitor atmospheric humidity in the installation room.
- Check vessel regularly for the collection of condensed water.
 - Check vessel regularly for damage to surface or material damage

This list is not complete.

9.5.4 General conduct in the case of an accident

In the case of an accident from oxygen deficiency the following regulations should be observed.

- Secure the surrounding area to avoid any subsequent accidents.
- Act quickly.
 - The rescuers must take measures to protect themselves (respiratory protection device).
- Move the injured persons from the hazardous area.
- Observe the company instructions for emergencies.
- Ventilate the rooms affected sufficiently.
- Investigate the cause of the accident.

This list is not complete.

9.6 Oxygen enrichment

9.6.1 Dangers

Oxygen enrichment may increase the danger of explosion and fire.

9.6.2 Causes

Oxygen may be condensed from the air if liquid nitrogen is used and similarly be liquefied because the boiling point of oxygen (approx. -183°C) is above that of nitrogen (-196°C).

9.6.3 Recommendations

The following points must be considered in the case of oxygen enrichment:

- Do not smoke.
- Where possible, keep easily inflammable materials away from the vessel.
 - Remove all sources of fire (naked flame and light, spark producers, matches, lighters etc.).
- Ventilate installation rooms constantly and appropriately.
- Clean floor regularly.
- Train personnel.
- Wear personal protective equipment.
- Check oxygen content constantly.
- Always carry an oxygen metre.

This list is not complete

9.7 Surrounding area of the machine

9.7.1 Rooms

The room in which the machine is located must:

- permit operation without danger to the employees
- have a constantly running and appropriate ventilation system
 - have a level and non-porous floor that is also able to bear the load of the vessel
 - have safety datasheets on liquid nitrogen visible for all to see
- prevent unauthorised access
- permit the safe filling of the vessel
 - permit accessibility to the vessel for inspection, cleaning and maintenance

This list is not complete.

10 Disposal

Please observe the respective statutory requirements with respect to disposal.

Information on disposal of electrical and electronic machines in the European Community.

Within the European Community the disposal of electrically operated devices is regulated by national provisions that are based on the EU Directive 2002/96/EC on Waste Electrical and Electronic Equipment (WEEE).

Accordingly, all machines supplied after 13.08.2005 in the business-to-business area to which this product is classified, may no longer be disposed of with municipal or household waste. To document this they have the following label:

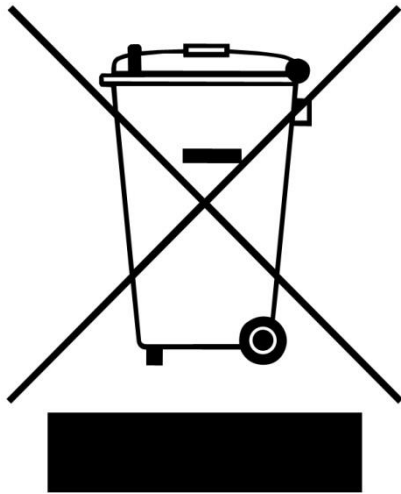

Fig. 51: Disposal label

Since the disposal regulations within the EU may differ from country to country we would request you to consult your supplier.

11 Index

4

4 A50

5

5ml Mahlbecher einsetzen36, 37

5ml Mahlbecher Position37

A

Ambient temperature13

Amendment status6

Amperage19

Assign/change memory space42

Atmospheric humidity13

Automatic precooling43

B

Bar code19

bS48

C

Capacity19

Causes 58, 59, 60, 61

CE marking19

Changes6

Checks56

Clean55

Cleaning55

Cold air outlet25

Condensation24

Condensation collecting filter16, 55

Confirmation10

Connecting the coolant feed21

Connection cable20

Cooling jacket seal22

Copyright6

Create/change a program42

cryo cycles39

Cryogenic burns59

D

Danger of explosion60

Dangers 58, 59, 60, 61

Decrease of sample volume during grinding
process52

Degree of protection11

Delete program42

Depth12

Device designation19

Diagram of the cooling system23

Dimensions12

Display of the grinding parameters41

Display of the operating hours48

Display of the software version49

Displays30

Disposal63

Disposal label19, 63

E

Electrical connection20

Emission value with regard to workplace11

Emissions11

Ending the grinding process47

Eppendorf37

Eppendorf Reaktionsgefäß37

Error messages54

Exhaust hose26

Explanations of the grinding cycles38

Explanations of the safety instructions7

External fuse20

F

Fill level27

Final fineness levels27

Flashing of the remaining time LED47

frequency 1/s39

Frequency range45

Front view28

Function of the hood switch56

Functions30

Fuse holder50

Fuse strength19

Fuse type19

G

G 1/4 inch24

General51, 57

General conduct in the case of an accident. 59, 61

General rules of conduct for splashes with liquid
nitrogen60

General safety instructions8

Glass fuses50

Grinding cycles43

Grinding frequency45

Grinding jar

filling level52

inserting32

Grinding jar volumes27

Grinding time44

Grinding time39

Grinding with cooling39

Grinding with program41

Grinding without cooling38

Grinding without program41

Grip18

H

H4056

Height12

Hood51

I

Increase of sample volume during grinding
process52

Insert the adapter for 4/2 x 5 ml grinding jar36

Inserting and removing CryoMill special

grinding jar	32
Inserting the cooling jacket seal	36
Inserting the cooling jacket sealing plug	36
Installation	13
Installation height	14
Installation of the device	14
Installation site	
conditions	13
Intermediate cooling	44
Intermediate cooling time	39
Interrupting and continuing the grinding process	46

K

Kühlmantel	33, 36, 37
------------------	------------

L

Laboratory mill	11
Layer of ice	24
Liquid nitrogen supply interrupted	47
L_{pAeq}	11

M

Mahlbecher einsetzen	33
Mahlbecher sichern	34
Mahlbecher Sicherung	33
Mahlbecheradapter einsetzen	37
Mahlbechersicherung lösen	33
Mains frequency	19
Maintenance	55
Manual	6
Manufacturer's address	19
Materials	27
Maximum relative humidity	13
Moderate or mild injury	7

N

Name of machine model	27
Noise values	11
Notes on the manual	6

O

Öffnungshilfe verwenden	36
Opening aids	35
Opening gap	56
Operating controls	30
Operating elements and displays	28
Operating hours	48
Operating hours display	48
Operating hours display	48
Operating software display	49
Operating the device	27
Operating time	48
Operation	15
Optimal grinding jar filling	27
Original parameters	51
Outlet for gaseous nitrogen	25
Oxygen deficiency	58
Oxygen enrichment	61

P

Packaging	13
-----------------	----

Part number	19
Power version	19
Precooling	43
Precooling	39
Precooling with definable precooling time	43
pressure relief	25
pressure relieve	25
Programme mode	41
property damage	7
Protective equipment	11
Pulling out the condensation collecting filter	16

Q
Quantities of sample material and feed sizes 52

R

Rated power	12
reaction vial	37
Reaktionsgefäße einsetzen	38
Rear view	28
Recommendations	59, 60, 61
Recovery of the samples	27
Regulations for the place of installation	20
Remaining grinding time	51
Removing the liquid nitrogen feed line	25
Removing the liquid nitrogen feed line	25
Repair	9
Replacing the machine fuses	50
Required floor space	12
Rooms	62

S

Safety and occupational health instructions	57
Safety functions and fault display	54
Safety instructions on the handling of liquid nitrogen	58
Safety warnings	7
Seal	22
Selection of a program	41
Sequence of a single grinding cycle	39
Sequence of two grinding cycles	40
Serial number	19
serious injury	7
Service Address	9
Setting grinding cycles	42
Setting precooling	43
Setting the duration of intermediate cooling	44
Setting the grinding cycles	42
Setting the grinding frequency	45
Setting the grinding time	44
Setting the precooling time	43
Single grinding cycle	39
Software	49
Special grinding jars	27
Starting the grinding process	46
Starting the grinding process	46
Stopping the grinding process	47
Summary table of device parts	29
Supply line pressure	24
Surrounding of the machine	62

T		
T 4 A	50	
Target group	27	
Target group	8	
Technical data	11	
Temperature fluctuation and condensed water ..	13	
The grinding process	51	
threaded connector	24	
Total operating time	48	
Transport	13, 15	
Transportation lock	15	
removing	15	
Type plate	19, 20	
description	19	
U		
UKCA marking	19	
		Use of the device for the intended purpose
		27
		V
		vapour plume
		14
		Version of the operating software
		49
		Voluminous materials.....
		27
		W
		Wear.....
		55
		Wearing parts.....
		55
		Weight.....
		12, 19
		Width
		12
		Working instructions.....
		51
		Working instructions.....
		53
		Y
		Year of production.....
		19

CRYOGENIC MIXER MILL

CryoMill | 20.749.xxxx

EU DECLARATION OF CONFORMITY

We, represented by the undersigned, hereby declare that the above device complies with the following directives and harmonised standards:

Machinery Directive 2006/42/EC

Applied standards, in particular:

DIN EN ISO 12100	Machine Safety - General Design Principles
DIN EN 61010-1	Safety Regulations for Electrical Measurement, Control, Regulation and Laboratory Devices

Electromagnetic compatibility 2014/30/EU (tested at 230 V, 50 Hz)

Applied standards, in particular:

EN 55011	Industrial, scientific and medical equipment - Radio-frequency disturbance characteristics - Limits and methods of measurement
DIN EN 61326-1	Electrical equipment for measurement, control and laboratory use - EMC requirements

Restriction of hazardous substances (RoHS) 2011/65/EU

Authorised person for compilation of the technical documentation:

Julia Kürten (Technical Documentation)

Furthermore, we declare that the relevant technical documentation for the above device has been prepared in accordance with Annex VII Part A of the Machinery Directive and we undertake to submit the documentation to the market surveillance authorities on request.

In the event of a modification of the device not agreed on by Retsch GmbH, as well as the use of non-approved spare parts or accessories, this declaration loses its validity.

Retsch GmbH

Haan, 09/2023



Dr. Frank Janetta, Head of Development





Retsch[®]

Copyright

© Copyright by
Retsch GmbH
Retsch-Allee 1-5
42781 Haan
Germany