

Manual

Mixer Mill MM 400

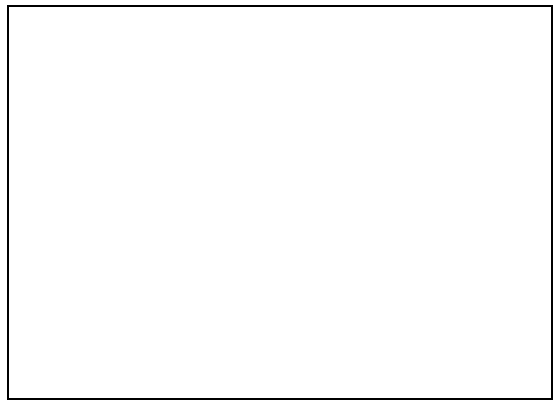

Translation

Retsch[®]

Copyright

© Copyright by
Retsch GmbH
Retsch-Allee 1-5
42781 Haan
Germany

Table of Contents

1	Notes on the manual	7
1.1	Disclaimer	7
1.2	Copyright	7
1.3	Explanation of signs and symbols	7
1.4	Explanations of the Safety Instructions	8
2	Safety	9
2.1	Intended use of the device	9
2.2	Improper use	9
2.3	Obligations of the operating company	10
2.3.1	Provisions	10
2.3.2	Personnel	10
2.3.3	Workstation and device	10
2.3.4	Qualification of personnel	11
2.3.5	Personal protective equipment (PPE)	11
2.4	Protective Equipment	11
2.5	Repairs	12
2.6	Preventing risks during normal operation	12
2.7	Preventing damage to equipment	13
2.8	Safety instructions on the handling of liquid nitrogen (Oxygen deficiency)	13
2.8.1	Dangers	13
2.8.2	Causes	14
2.8.3	Recommendations	14
2.8.4	General conduct in the case of an accident	14
2.9	Safety instructions on the handling of liquid nitrogen (Cryogenic burns)	14
2.9.1	Dangers	14
2.9.2	Causes	15
2.9.2.1	Burns through splashes	15
2.9.2.2	Burns through contact	15
2.9.3	Recommendations	15
2.9.4	General rules of conduct for splashes with liquid nitrogen	15
2.9.4.1	To the eyes	15
2.9.4.2	On the skin	15
2.10	Confirmation Form for the Managing Operator	16
3	The Mixer Mill MM 400	17
3.1	Technical data	17
3.2	Emissions	19
3.3	Views of the device	20
3.3.1	Front	20
3.3.2	View of the grinding jar support	21
3.3.3	Back	22
3.4	Signs on the device	23
3.5	Type Plate Description	24
4	Packaging, Transport and Installation	25
4.1	Accessories included with delivery	25
4.2	Packaging	25
4.3	Transport	25
4.4	Temperature Fluctuations and Condensation	26
4.5	Conditions for the Installation Site	26
4.6	Remove packaging	27
4.7	Removing the Transportation Lock	28
5	First Commissioning	29
5.1	Electrical Connection	29

5.2	Connecting the device to the power supply	30
6	Operating the Device	31
6.1	Switching the device on/off	32
6.2	Opening and Closing of the Device	32
6.3	Specifications regarding grinding balls and grinding jars	33
6.3.1	Grinding Jar Identification	34
6.3.2	Recommended maximum ball sizes	34
6.3.3	Recommended Grinding Jar Filling	34
6.4	Opening aid.....	35
6.5	Preparing the grinding jar	36
6.5.1	Opening the grinding jar	37
6.5.2	Filling the grinding jar.....	38
6.5.3	Closing the grinding jar	38
6.6	Inserting the Grinding Jar	39
6.6.1	Opening the grinding jar support	39
6.6.2	Inserting the grinding jar	40
6.7	Grinding process.....	41
6.8	Starting the grinding process	42
6.9	Removing the sample material	42
6.10	Special grinding methods	44
6.10.1	Cryogenic grinding.....	44
6.10.2	Wet Grinding with Highly Flammable Materials.....	45
7	Device control.....	46
7.1	Menu interface on the touchscreen	47
7.2	Function elements	48
7.3	Menu navigation	51
7.4	Main menu	52
7.5	Controlling the grinding process	53
7.5.1	Starting the grinding process	53
7.5.2	Pausing the grinding process	53
7.5.3	Stopping the grinding process	54
7.5.4	Grinding process successfully completed	54
7.6	Program mode	54
7.6.1	Select a Program	55
7.6.2	Edit a Program.....	57
7.6.3	Save a Programme	58
7.6.4	Delete a Programme.....	58
7.7	Cycle programme mode	58
7.7.1	Selecting the cycle programme	60
7.7.2	Editing the cycle programme	61
7.7.3	Saving the cycle programme	62
7.7.4	Deleting the cycle programme	62
7.8	System settings	62
7.8.1	Brightness	63
7.8.2	MyRetsch	63
7.8.3	Device information	64
7.8.4	Signalling device	64
7.8.5	Date and time.....	65
7.8.6	Service Environment.....	65
7.8.6.1	Software update.....	65
7.8.6.2	Calibration.....	66
8	Error Messages and Information Notes	67
8.1	Error Messages	67
9	Installing additional equipment	69

9.1	Adapter for conical centrifuge tubes and adapter for 30 ml wide mouth bottles	69
9.2	Adapter for 4 x 5 ml steel grinding jars	71
10	Servicing	72
10.1	Cleaning.....	72
10.1.1	Cleaning the outside of the device	73
10.1.2	Cleaning the collecting tray.....	73
10.1.3	Cleaning the inside	73
10.1.4	Cleaning the grinding jar.....	73
10.1.5	Cleaning the grinding balls	73
10.2	Maintenance	73
10.3	Wear	74
10.3.1	Replacing the Fuses	74
10.4	Returning for repair and maintenance	75
11	Accessories	76
12	Disposal.....	77
13	Index	79

1 Notes on the manual

This manual provides technical guidelines for the safe operation of the device. Read this manual through carefully before installing, putting into service and operating the device. Reading and understanding this manual is essential for handling the device safely and as intended.

This manual does not contain any repair instructions. Please contact your supplier or contact Retsch GmbH directly if anything is unclear or you have questions about these guidelines or the device, or in the case of any faults or necessary repairs.

You can find further information about your device at <https://www.retsch.com> on the pages for the specific device concerned.

Amendment status:

The document amendment 0000 of the "Mixer Mill MM 400" manual has been prepared in accordance with the Directive of Machinery 2006/42/EC.

1.1 Disclaimer

This manual has been prepared with great care. We reserve the right to make technical changes. We assume no liability for personal injuries resulting from the failure to follow the safety information and warnings in this manual. No liability will be assumed for damage to property resulting from the failure to follow the information in this manual.

1.2 Copyright

This document or parts of it or its content may not be reproduced, distributed, edited or copied in any form without prior written permission of Retsch GmbH. Damage claims shall be asserted in the case of infringements.

1.3 Explanation of signs and symbols

In this manual, the following signs and symbols are used:

Signs and symbols	Meaning
①	Reference to recommendation and/or important information.
Bold font	Labelling of an important term.
• • •	Lists
(1), (2), (...) (A), (B), (..)	The components have a fixed marking.
⇒	Action steps of instructions.
→	Result of an action step



In the descriptions of these operating instructions, the **Retsch mixer mill MM 400** is mostly referred to as a **device**.

1.4 Explanations of the Safety Instructions

DANGER

D1.0000

Risk of fatal injuries
Source of danger

- Possible consequences if the danger is ignored.
- **Instructions and information on how to avoid the risk.**

Fatal or serious injuries may result if the “Danger” sign is disregarded. There is a **very high risk** of a life-threatening accident or lasting personal injury. The signal word **⚠ DANGER** is additionally used in the running text or in instructions.

WARNING

W1.0000

Risk of life-threatening or serious injuries
Source of danger

- Possible consequences if the danger is ignored.
- **Instructions and information on how to avoid the risk.**

Life-threatening or serious injuries may result if the “Warning” sign is disregarded. There is an **increased risk** of a serious accident or of a possibly fatal personal injury. The signal word **⚠ WARNING** is additionally used in the running text or in instructions.

CAUTION

C1.0000

Risk of injuries
Source of danger

- Possible consequences if the danger is ignored.
- **Instructions and information on how to avoid the risk.**

Average to slight injuries may result if the “Caution” sign is disregarded. There is an average or slight risk of an accident or personal injury. The signal word **⚠ CAUTION** is additionally used in the running text or in instructions.

NOTICE

N1.0000

Type of damage to property
Source of the damage to property

- Possible consequences if the information is ignored.
- **Instructions and information on how to avoid the damage to property.**

Damage to property may result if the information is disregarded. The signal word **NOTICE** is additionally used in the running text or in instructions.

2 Safety

CAUTION

C2.0002

Risk of injury

Lack of knowledge of the manual

- The manual contains all safety-related information. Disregarding the manual can therefore lead to injuries.
- **Read the manual carefully before operating the device.**



Target group:

The MM 400 has been designed for preparing samples in a laboratory environment. laboratory environment. This manual is therefore directed at persons who work with this device in a comparable environment and who already have experience with similar equipment.

The MM 400 is a modern, efficient, state-of-the-art product from Retsch GmbH. Its reliability is ensured when used as intended and with knowledge of this technical documentation.

2.1 Intended use of the device

The MM 400 is designed for crushing, grinding, mixing and homogenising soft, medium-hard, hard, fibrous, elastic and brittle materials in dry and wet condition up to a particle size of 8 mm. The device is also suitable for the cryogenic grinding of sample materials.

As a laboratory device, the MM 400 is only to be used for the preparation of samples and not as a production machine.

The device is designed for stationary operation in a dry and clean working environment.

Operators and operating personnel must have read the operating instructions and be familiar with the full range of functions of the device.

2.2 Improper use

The MM 400 may only be used as intended.

Any uses other than the described intended use are regarded as improper use.

The MM 400 is **not** suitable for processing sample materials that can form explosive air mixtures.

Any form of claims for damage to equipment or personal injury resulting from improper use and/or the failure to comply with the safety instructions shall be ruled out.

2.3 Obligations of the operating company

2.3.1 Provisions

The user bears responsibility for ensuring that people working with the device and the corresponding equipment have taken note of and understood all relevant safety regulations.

2.3.2 Personnel

- Ensure that only trained personnel are deployed whose training and experience enable them to recognise risks and avoid potential hazards.
- Staff should be given regular training on using the device, and in particular regarding sudden events.
- Only allow trainee staff to work on the device when they are being supervised by qualified personnel.
- Check the safety awareness of staff regularly.
- Define staff responsibilities according to qualification and job description.
- Provide staff with personal protective equipment (PPE).
- Ensure that the following conditions have been met:
 - Staff have read and understood this Manual, and in particular the chapter on [Safety](#).
 - Staff are aware and take note of the relevant accident prevention and safety regulations.
 - Staff wear the designated personal protective equipment (PPE) when working with the device.

2.3.3 Workstation and device

- Ensure that there is sufficient lighting and ventilation at the workstation.
- Ensure that the exhaust air is properly conducted outside.
- All signs on the device must be kept in a legible condition.
- Ensure that all inspections and servicing work prescribed in this Manual are carried out.

2.3.4 Qualification of personnel

Work/operating phase	Qualification
Transport Installation Commissioning Operation Controlling Servicing Disposal	Qualified employee who has been trained in the safe use of the device.
Work on the electrical equipment on the device	Electrician who, on the basis of his/her training, knowledge and experience is able to evaluate the work assigned and recognise potential hazards.

2.3.5 Personal protective equipment (PPE)

Work/operating phase	Personal protective equipment (PPE)
Transport Installation	Safety footwear
Commissioning Servicing	No PPE needed.
Disposal	Safety footwear
Normal operation (operation and control)	Hearing protection Possibly protective gloves to remove extremely hot or cold sample material. Protective gloves and goggles for cryogenic grinding using liquid nitrogen.

2.4 Protective Equipment

Emergency stop switch

The device is **not** factory-equipped with an emergency stop switch. In an emergency, the device must be shut down by pressing the main switch or by disconnecting the device from the power supply.

2.5 Repairs

This manual does not contain any repair instructions. For safety reasons, repairs may only be carried out by Retsch GmbH or an authorised representative or by qualified service technicians.

In case of repair, please inform...

- ...the Retsch GmbH representative in your country,
- ...your supplier, or
- ...Retsch GmbH directly.

Service address:

2.6 Preventing risks during normal operation

The failure to comply with the following safety instructions constitutes improper use and presents a risk to personnel and to operational safety.

Transport and installation

- Do not carry the device by yourself during transport and installation.
- Wear safety footwear for transport and installation.
- Only connect the device to sockets with a PE protective conductor.
- When connecting the device, the values on the type plate must correspond to those for the power connection.

Operation

- Read the manual before commissioning the device.
- Only operate the device at a workstation of sufficient size that offers adequate stability.
- Check the mains lead for damage before operating the device.
- Never operate the device if damage is visible or suspected.
- Only operate the device according to the technical application limits.
- During operation, do not wear any jewellery, wear your hair down or wear a tie or similar loose item of clothing.
- Wearing hearing protection during operation.
- Before operating the device, take measures that take account of restricted communication during operation of the device.
- Pay attention to your surroundings during grinding because the noise makes it more difficult to pick up acoustic signals.
- Do not operate the device in potentially explosive atmospheres.

- Take note of the safety data sheets for the samples and follow instructions by taking appropriate measures in advance.
- Do not grind any explosive and/or flammable substances.
- Do not grind any substances that might become explosive and/or flammable during grinding.
- The components that come into contact with sample material can get very hot or cold during operation. Before removing the samples, wait for the temperature to adjust, and wear protective gloves if necessary.
- Always wear protective gloves and goggles when handling liquid nitrogen for cryogenic grinding.
- Under no circumstances fill liquid nitrogen or dry ice into the grinding jar and then close the jar. The high pressure that arises in the jar would burst the grinding jar open.

Servicing and repair

- Before servicing, switch the device off at the main switch.
- Only clean the device with a dry or damp cloth.
- Do not clean the device with compressed air.
- Have all repairs carried out by the device manufacturer or by an authorised agent.

2.7 Preventing damage to equipment

- Protect the device against condensation if large fluctuations in temperature are to be expected (e.g. during air transport).
- Do not knock, shake or throw the device during transport and installation.
- Comply with conditions at the installation site when installing the device.
- Under no circumstances fill liquid nitrogen or dry ice into the grinding jar and then close the jar. The high pressure that arises in the jar would burst the grinding jar open.
- Only clean the device with a dry or damp cloth.
- Do not use any solvent or aggressive detergent for cleaning.
- Only use original spare parts for maintenance work.

2.8 Safety instructions on the handling of liquid nitrogen (Oxygen deficiency)

The main components of air according to volumes are as follows:

- Oxygen O₂ 21 %
- Nitrogen N₂ 78 %
- Argon Ar 1 %

The gases contained in the atmosphere are not toxic. However, a change in concentration (in particular changes to the oxygen concentration) may have effects on life and burns. It is therefore essential for the air breathed in to contain sufficient oxygen (> 19 %).

Humans cannot detect changes in the composition of air within the time that will actually be necessary because the components are colourless and odourless.

2.8.1 Dangers

A danger of suffocation exists as a result of the normal evaporation of the liquid nitrogen that pushes out the oxygen in the air. An oxygen deficiency is dangerous and can cause death through suffocation. The reaction of the organism to oxygen deficiency will differ greatly

depending on the individual. It is not possible to provide precise and generally applicable information on the symptoms of an oxygen deficiency.

Example: under normal conditions (20° C; 1013 mbars) 1 l liquid nitrogen evaporates to produce 680 l nitrogen gas.

2.8.2 Causes

An oxygen deficiency may arise during the following work or in the following conditions:

- Nitrogen as liquid or gas
- Natural evaporation of liquid nitrogen
- Refilling of liquid nitrogen
- Leaks in containers for liquid or gaseous nitrogen
- Defect in the air feed or outlet
- Tipping over of the container

This list is not complete.

2.8.3 Recommendations

In order to prevent the danger of an oxygen deficiency, the following measures must be taken.

The vessel

- must be kept in a vertical position.
- must be provided with a suitable insulating lid.
- must be protected from direct sunlight and may not be set up near heat sources.
- may not be transported in vehicles in filled state.
- must be protected from impact, knocks and rapid movements.

- Ventilate all installation rooms constantly and appropriately.
- Wear protective clothing (suitable gloves, goggles or face protection and safety shoes).
- Check the oxygen content of the room constantly.
- Always carry an oxygen metre.
- Only trained personnel may work with liquid nitrogen.

This list is not complete.

2.8.4 General conduct in the case of an accident

In the case of an accident from oxygen deficiency the following regulations should be observed.

- Secure the surrounding area to avoid any subsequent accidents.
- Act quickly.
- The rescuers must take measures to protect themselves (respiratory protection device).
- Move the injured persons from the hazardous area.
- Observe the company instructions for emergencies.
- Ventilate the rooms affected sufficiently.
- Investigate the cause of the accident.

This list is not complete.

2.9 Safety instructions on the handling of liquid nitrogen (Cryogenic burns)

Liquid nitrogen is very cold (-196 °C).

The surfaces of vessels that were in contact in liquid nitrogen (in particular during the filling process) may cause skin burns on contact.

2.9.1 Dangers

Cryogenic liquids may:

- bring about burns to the human body

- make specific materials (metal and plastic) that are not suitable for low temperatures brittle
- generate strong misting depending on atmospheric humidity

2.9.2 Causes

There are two types of cryogenic burns:

2.9.2.1 Burns through splashes

When handling samples and in general when handling liquid nitrogen, personnel must protect themselves from splashes. They can cause cryogenic burns with serious consequential damage, in particular to eyes and face.

2.9.2.2 Burns through contact

Contact of the skin with cold material causes frostbite or cryogenic burns. The interior of vessels or the samples may never be touched or held with bare hands.

2.9.3 Recommendations

In order to prevent the danger of burning the following points must be observed:

- Never bring cryogenic liquids in contact with the skin.
 - Never touch the cold non-isolated or iced walls of a vessel.
 - Wear personal protective equipment (suitable gloves, goggles or face protection and safety shoes).
- Keep the vessel upright.
 - Use suitable material (e.g. metal hose or PTFE hose) to refill.
- Train personnel.

This list is not complete.

2.9.4 General rules of conduct for splashes with liquid nitrogen

2.9.4.1 To the eyes

- Rinse eyes with much water for 15 min.
- Follow the company instructions for emergencies.
- Consult a doctor

2.9.4.2 On the skin

- Do not rub.
- If possible remove or loosen clothing.
- Slowly and gradually warm the parts affected.
- Do not apply anything to the burnt area.
- Follow the company instructions for emergencies.
- Consult a doctor.

Both lists are not complete.

2.10 Confirmation Form for the Managing Operator

This manual contains essential instructions for operating and maintaining the device which must be strictly observed. It is essential that they be read by the user and by the qualified staff responsible for the device before the device is commissioned. This manual must be available and accessible at the place of use at all times.

The user of the device herewith confirms to the managing operator (owner) that he has received sufficient instructions about the operation and maintenance of the system. The user has received the manual, has read and taken note of its contents and consequently has all the information required for safe operation and is sufficiently familiar with the device.

The managing operator should for legal protection have the user confirm the instruction about the operation of the device.

I have read and taken note of the contents of all chapters in this manual as well as all safety instructions and warnings.

User

Surname, first name (block letters)

Position in the company

Place, date and signature

Managing operator or service technician

Surname, first name (block letters)

Position in the company

Place, date and signature

3 The Mixer Mill MM 400

The MM 400 of the Retsch GmbH is a laboratory device and is used for the preparation of samples.

The device enables fast crushing, grinding, mixing and homogenisation of soft, medium-hard, hard, fibrous, elastic, and brittle materials in dry and wet condition up to a particle size of 8 mm. The device is also suitable for the cryogenic grinding of sample materials. Depending on the properties of the material and the grinding parameters, final fineness levels of up to 5 µm can be achieved.

Due to the effective grinding process in a closed system, the device ensures a material-friendly, analysis-oriented preparation of samples in the shortest possible time.

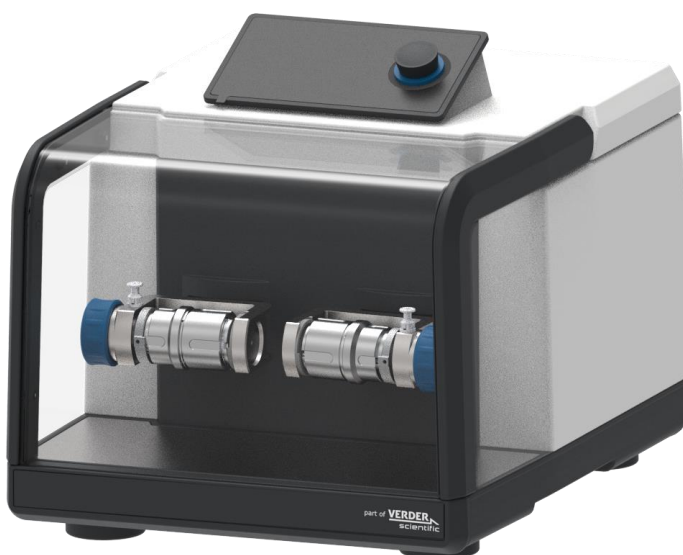

Fig. 1: The mixer mill MM 400

NOTICE: This device is not designed as a production machine and for continuous operation, but as a laboratory device, intended for single-shift intermittent periodic operation of 8 hours per day.

3.1 Technical data

Areas of application	
Applications	Crushing (dry and wet), mixing, homogenising, cell disruption, cryogenic milling, mechanochemistry
Areas of application	Agricultural sciences, building materials, biology, chemistry / plastics, geology / metallurgy, glass / ceramics, food, mechanical engineering / electrical engineering, medicine / pharmaceuticals, environment / recycling
Feed material	Hard, medium-hard, soft, brittle, elastic, fibrous

Operational data	
Mains connection (depending on the variant)	1~, 100-240V, 50/60Hz, 185W
Mains voltage fluctuations	+/- 10%
Overvoltage category	Category II
Degree of pollution	Degree II
Degree of protection	IP30
Electromagnetic compatibility (EMC)	EMC Class B according to EN 55011

Values for grinding	
Crushing principle	Bounce, friction
Dry grinding	Yes
Wet grinding	Yes
Cryogenic grinding	Yes
Number of grinding stations	2
Maximum feed amount	2 x 20ml
Feed size	8mm
Maximum achievable final fineness level	~ 5 µm
Vibration frequency setting	Digital, 3–30Hz Step size 0.5Hz
Grinding jars (materials)	Hardened steel Stainless steel Tungsten carbide Agate Zirconia Polytetrafluoroethylene (PTFE) Polymethyl methacrylate (PMMA)
Grinding jar sizes	1.5ml / 5ml / 10ml / 25ml / 35ml / 50ml
Operation	4.3-inch touch display with rotary knob
Grinding time setting	Digital, 10s – 8h In the cycle program mode, the total running time is limited to 99 hours. 10 s – 1 min: 1 s steps 1 min – 3 min: 5 s steps 3 min – 10 min: 10 s steps 10 min – 30 min: 30 s steps 30 min – 1 h: 1 min steps 1 h – 3 h: 5 min steps 3 h – 8 h: 10 min steps
Storable SOPs (Standard Operating Procedures)	12
Storable cycle programs	6 (up to 99 repeats)

Dimensions and weight	
Height	350mm
Width	385mm
Depth	470mm
Height with grinding chamber open	640mm

Weight	Ca. 27.5kg
Required floor space	400x500mm

Site conditions	
Installation height	Max. 2000 m above sea level NN
Ambient temperature	5°C to 40°C
Humidity	Maximum relative humidity 80% to 31°C, decreasing linearly up to 50% relative humidity at 40°C

3.2 Emissions

⚠ CAUTION

C.0020

Risk of injury caused by not hearing acoustic signals

Loud grinding noise

- Loud grinding noise may result in not hearing acoustic warning signals, leading to injuries.
- **Take the volume of grinding noise into consideration when designing the acoustic signals in the working environment.**
- **Where necessary, use additional visual signals.**

⚠ CAUTION

C3.0077

Risk of hearing loss

High sound level

- The sound level may be high depending on the type of material, the number of balls used, the set grinding frequency and the grinding time. Excess noise in terms of intensity and duration can lead to impairments or permanent damage to hearing.
- **Ensure you take suitable soundproofing measures.**
- **Wear hearing protection if there is loud or lasting noise.**



Noise levels:

The noise levels are influenced by the material to be ground, the feed particle size and the set frequency.

Example 1	
Container	2 steel grinding jars (25ml)
Shredding organ	1 steel ball each (20mm)
Feed material	Broken glass (approx. 4.0mm - 6.0mm)
Feed quantity	8ml
Speed	30Hz

Under these operating conditions, the workplace-related equivalent continuous noise level is $L_{eq} = 63.3 \text{ dB(A)}$.

Example 2	
Container	2 steel grinding jars (5ml)
Shredding organ	2 tungsten carbide balls each (7mm)
Feed material	Broken glass (approx. 1.0mm – 1.5mm)
Feed quantity	1.5ml
Speed	30Hz

Under these operating conditions, the workplace-related equivalent continuous noise level is $L_{eq} = 53.4\text{dB(A)}$.

3.3 Views of the device

 The numbering of components in the following views of the device is fixed and is used in further figures of components in the Manual.

3.3.1 Front



Fig. 2:Device hood closed



Fig. 3: Device hood opened

No.	Component	Function
1	Device hood	Seals the grinding chamber of the device.
2	Touch display with rotary knob	For controlling the device. Selection and configuration of grinding parameters.
3	Grinding stations	Position of the grinding jar holders for holding the grinding jars.
4	Transport safety device	Protects the device from damage caused by vibration during transport.

3.3.2 View of the grinding jar support

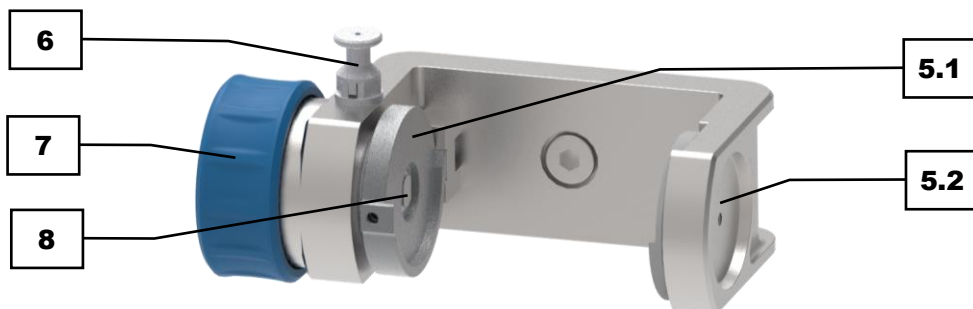

Fig. 4: Grinding jar holder

No.	Component	Function
5.1	Movable pressure plate	For holding the grinding jar in the grinding jar holder. Locked via the locking pin.
5.2	Fixed pressure plate	For holding the grinding jar in the grinding jar holder.

No.	Component	Function
6	Locking pin	Prevents the grinding jar lock from opening.
7	Locking wheel	To tighten or loosen the grinding jars in the grinding jar holder.
8	Centering	For centering the grinding jar in the grinding jar holder.

3.3.3 Back



Fig. 5:Back of the device

No.	Component	Function
9	USB interface	For connecting a USB data carrier to update the control software.
10	Ethernet interface	Interface for the service.
11	Main switch	Turns the device on or off
12	Device socket	Connection for the power cord.
13	Air vents	To conduct the waste heat.

3.4 Signs on the device



Fig. 6: Back of the device

No.	Component	Function
14	Wear hearing protectors	When operating the device for a longer period of time, we recommend wearing hearing protectors.
15	Read the operating instructions	The operating instructions for the device must be read before start-up and operation.
16	Power warning	Caution electric shock! The housing may only be opened by trained personnel. Pull out the mains plug before maintenance!
17	Type label	Information on the device.

3.5 Type Plate Description

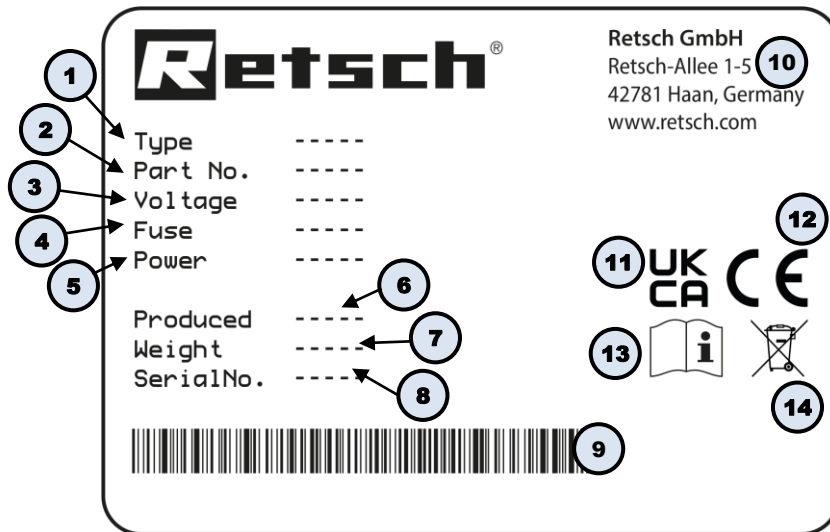

Fig. 7: Type plate

- 1 Device designation
- 2 Part number
- 3 Power version, Mains frequency
- 4 Fuse type and fuse strength
- 5 Capacity, Amperage
- 6 Year of production
- 7 Weight
- 8 Serial number
- 9 Bar code
- 10 Manufacturer's address
- 11 UKCA marking
- 12 CE marking
- 13 Safety warning: Read the manual
- 14 Disposal label

① In the case of queries please provide the device designation (1) or part number (2), as well as the serial number (8) of the device.

4 Packaging, Transport and Installation

4.1 Accessories included with delivery

4.2 Packaging

The packaging has been adapted to the mode of transport. It complies with the generally applicable packaging guidelines.

NOTICE

N2.0001

Complaint or return

Keeping the packaging

- Inadequate packaging and insufficient securing of the device can jeopardise the warranty claim in the event of a complaint or return.
- **Keep the packaging for the duration of the warranty period.**

4.3 Transport

WARNING

W2.0005

Risk of injury due to the device falling down

Lifting the device above head height

- The device can fall causing serious injuries when lifted above head height.
- **Never lift the device above head height!**



CAUTION

C4.0000

Risk of injury caused by the device falling down

Incorrect transport of the device

- Due to its weight, the device can cause injuries if it falls down.
- **Do not transport the device by yourself.**

Transport must be carried out according to the device properties and may only be facilitated by qualified personnel with the appropriate knowledge.

The safety instructions must be observed for transport.

NOTICE

N3.0017

Damage to components

Transport

- Mechanical or electronic components may be damaged during transport. The device must not be knocked, shaken or thrown during transport.
- **Move the device gently during transport.**

NOTICE

N4.0014

Complaints

Incomplete delivery or transport damage

- The forwarding agent and Retsch GmbH must be notified immediately in the event of transport damage. It is otherwise possible that subsequent complaints will not be recognised.
- **Please check the delivery on receipt of the device for its completeness and intactness.**
- **Notify your forwarding agent and Retsch GmbH within 24 hours.**

4.4 Temperature Fluctuations and Condensation

Temporary storage:

In case of an interim storage the device must be stored dry and within the specified ambient temperature range.

NOTICE

N5.0016

Damaged components due to condensation

Temperature fluctuations

- The device may be exposed to substantial fluctuations in temperature during transport. The ensuing condensation can damage electronic components.
- **Wait until the device has acclimatised before putting it into service.**

4.5 Conditions for the Installation Site

⚠ CAUTION

C5.0047

Risk of injury caused by the device falling

Incorrect installation of the device

- Due to its weight, the device can cause injuries if it falls.
- **Only operate the device on a sufficiently large, strong and stable workstation.**
- **Ensure that all of the device feet are securely supported.**

NOTICE

N6.0004

Setting up the device

Vibrations during operation

- Depending on the operating mode of the device, slight vibrations may occur.
- **Set up the device only on a vibration-free, plane and stable surface.**

NOTICE

N7.0002

Setting up the device

Disconnecting the device from the mains

- A separation of the device from the mains must be possible at any time.
- **Set up the device in such a way, that the connection for the power cable is always easily accessible.**

NOTICE

NB.0021

Ambient temperature

Temperatures outside the permitted range

- Electronic and mechanical components may be damaged.
- The performance data alters to an unknown extent.
- **Do not exceed or fall below the permitted temperature range (5 °C to 40 °C ambient temperature) of the device.**

NOTICE

NB.0015

Humidity

High relative humidity

- Electronic and mechanical components may be damaged.
 - The performance data alters to an unknown extent.
 - **The relative humidity in the vicinity of the device should be kept as low as possible.**
- Installation height: max. 2 000 m above sea level
 - Ambient temperature: 5 °C – 40 °C
 - Maximum relative humidity < 80 % (at ambient temperatures ≤ 31 °C)

For ambient temperatures U_T between 31 °C and 40 °C, the maximum relative humidity value L_F linearly decreases according to $L_F = -(U_T - 55) / 0.3$:

Ambient temperature	Max. rel. humidity
≤ 31 °C	80 %
33 °C	73.3 %
35 °C	66.7 %
37 °C	60 %
39 °C	53.3 %
40 °C	50 %

The MM 400 must be installed on a stable and solid surface. Vibrations from the device will otherwise be transmitted to the surroundings during the grinding process.

4.6 Remove packaging

Remove the packaging and take out the device as follows:

- ⇒ Place the device supplied in the box on a stable surface and open the box.
- ⇒ Carefully remove the device from the box.
- ⇒ Keep the carton and packing material in case you need to return the device.

4.7 Removing the Transportation Lock

WARNING

W3.0005

Risk of injury due to the device falling down
Lifting the device above head height

- The device can fall causing serious injuries when lifted above head height.
- **Never lift the device above head height!**

N10.0018

Transportation lock

Transport without transportation lock, or operation with transportation lock

- Mechanical components may be damaged.
- **Only transport the device with mounted transportation lock.**
- **Do not operate the device with built-in transportation lock.**

To avoid shaking of the device during transport, the device is equipped with a transport safety device at the factory. The transport safety device is located on the underside of the device and must be removed before using it for the first time. The tools required are included with the device.

- Remove the transport safety device as described below:
- ⇒ There is an arrow on the underside, which indicates the transport safety device.
 - ⇒ Carefully tip the device backwards or to the side and onto a soft surface.
 - ⇒ Loosen the screw in the middle of the underside and remove the transport safety device (4).
 - ⇒ Keep the transport safety device for future transport of the device.

NOTE When operating with the transport safety device in place, or transporting the device without the transport safety device, mechanical components may be damaged.

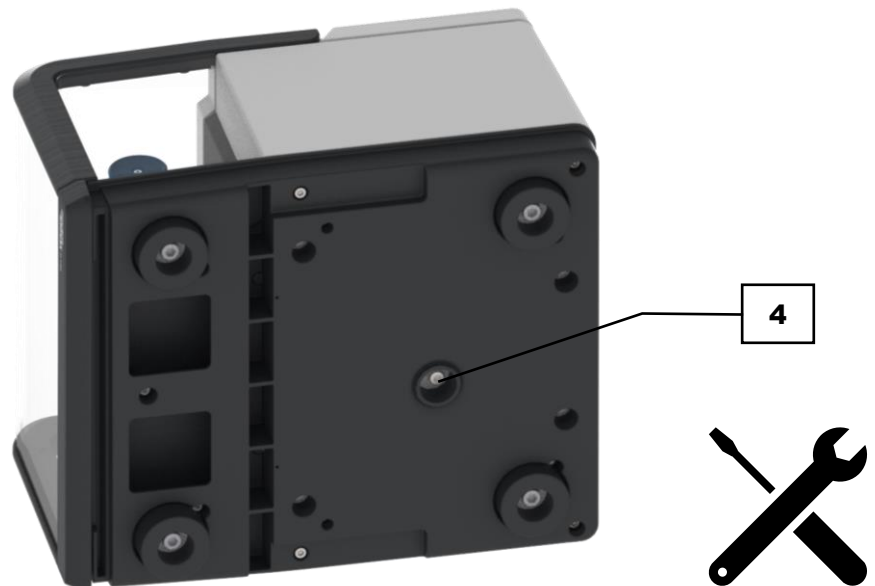

Fig. 8: Releasing the transport safety device

5 First Commissioning

5.1 Electrical Connection

⚠ WARNING W4.0015

Risk to life caused by an electric shock
 Connection to socket without a protective earth conductor

- Connecting the device to sockets without a protective earth conductor can lead to life-threatening injuries caused by an electric shock.
- **Always operate the device using sockets with a protective earth conductor (PE).**



⚠ WARNING W5.0002

Danger to life through electric shock
 Damaged power cable

- Operating the device with a damaged power cable or plug can lead to life-threatening injuries caused by an electric shock.
- **Before operating the device, check the power cable and plug for damage.**
- **Never operate the device with a damaged power cable or plug!**



NOTICE N11.0022

Electrical connection
 Failure to observe the values on the type plate

- Electronic and mechanical components may be damaged.
- **Connect the device only to a mains supply matching the values on the type plate.**

⚠ WARNING When connecting the power cable to the mains supply, use an external fuse that complies with the regulations applicable to the place of installation.

- Check the type plate for details on the necessary voltage, frequency, and maximum external current source fuse for the device.
- The listed values must agree with the existing mains supply.
- Only use the supplied power cable to connect the device to the mains supply.

The MM 400 must be connected to the power supply on site for initial commissioning.

Ensure the following before connecting the device to the power supply:

- The application site complies with the installation requirements;
- The device is securely and firmly in place;
- The power values for the device (type plate) correspond to the values of the power supply at the site.

5.2 Connecting the device to the power supply

Connect the device to the mains as described below:

- ⇒ Compare the voltage and frequency on the type label (17) of the device with the values on site.
- ⇒ Plug the supplied mains cable into the device socket (12).
- ⇒ Plug the other end of the mains cable into a socket at the installation site.
- ⇒ Carry out external protection measures according to the regulations of the place of installation.



Fig. 9:Facilitating the power connection

6 Operating the Device

WARNING

W6.0002

Danger to life through electric shock
 Damaged power cable

- Operating the device with a damaged power cable or plug can lead to life-threatening injuries caused by an electric shock.
- **Before operating the device, check the power cable and plug for damage.**
- **Never operate the device with a damaged power cable or plug!**

CAUTION

C6.0005

Risk of injury
 Potentially explosive atmosphere

- The device is not suitable for use in potentially explosive atmospheres. Operating the device in a potentially explosive atmosphere can lead to injuries caused by an explosion or fire.
- **Never operate the device in a potentially explosive atmosphere!**

CAUTION

C7.0077

Risk of hearing loss
 High sound level

- The sound level may be high depending on the type of material, the number of balls used, the set grinding frequency and the grinding time. Excess noise in terms of intensity and duration can lead to impairments or permanent damage to hearing.
- **Ensure you take suitable soundproofing measures.**
- **Wear hearing protection if there is loud or lasting noise.**

6.1 Switching the device on/off

Turn on the device as follows:

⇒ Switch on the device using the main switch (11) on the back of the device.

The opening and closing of the device hood (1) is indicated on the touch display (2).

⇒ Open the hood of the device (1) by hand completely and close it again. The device is now ready for operation.

Turn off the device as follows:

⇒ Switch off the device using the main switch (11) on the back of the device when the grinding process is not running.



Fig. 10: Main switch on the back of the device

6.2 Opening and Closing of the Device

Open the device as follows:

⇒ Lift the hood of the device (1) by hand and open it completely.

Close the device as follows:

⇒ Close the hood of the device (1) carefully by hand.

NOTE The hood of the device is equipped with damping. The cushioning ensures that the hood of the device does not slam shut uncontrollably. The damping of the hood of the device takes effect from an opening angle of 20°.

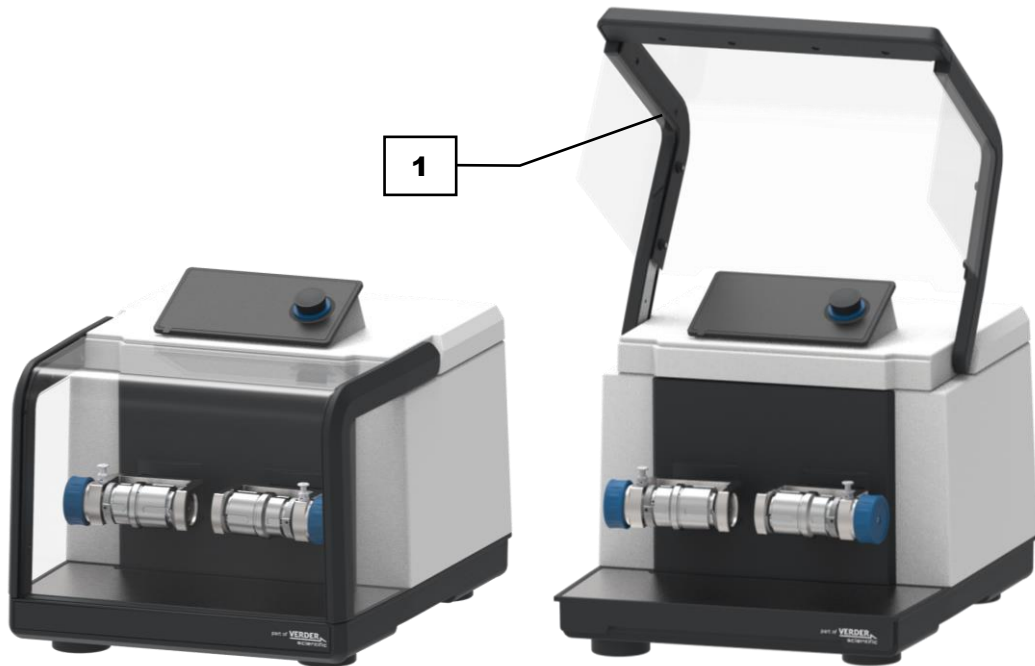

Fig. 11: Opening and closing the hood of the device

6.3 Specifications regarding grinding balls and grinding jars

A very large amount of energy is applied to the sample material on the MM 400. This large amount of energy also affects the grinding jars and the grinding balls.

Depending on the grinding jar size, the following recommendations therefore apply to the sample volume and ball sizes that can be used.

NOTICE

N12.0011

Wear or damage to the grinding balls and grinding jars

Use of different materials

- Greater wear or damage is possible when operating the device with grinding balls and grinding jars whose individual components are made of different materials.
- **Only use grinding balls and grinding jars made of the same material.**

NOTICE

N13.0000

Damage to the grinding jars

Incorrect filling of the grinding jars

- The grinding balls damage the grinding jar and the device if the grinding jars are not filled with any material or with insufficient material.
- **Do not operate the device without material in the grinding jars.**
- **The filling in the grinding jars must not be less than 25 % of the grinding jar volume.**

6.3.1 Grinding Jar Identification

All grinding jars and the corresponding grinding jar covers can be identified by labelling on the outside. The labelling indicates the size and material of the grinding jar.

6.3.2 Recommended maximum ball sizes

Grinding jar size	Ball size
1.5 ml	5 mm
5 ml	7 mm
10 ml	12 mm
25 ml	15 mm
35 ml	20 mm
50 ml	25 mm

6.3.3 Recommended Grinding Jar Filling

In addition to device settings, the fill level of the grinding jars is crucial for the success of grinding in the Mixer Mill. **When grinding bulk materials, a grinding jar filling should consist roughly of one third sample material and one third ball volume.** The remaining third is the empty grinding jar volume that the balls need in order to move. Please pay attention to the maximum permitted ball size for the material in question.

If an increase in volume or decrease in volume is to be expected during grinding, the sample volume can be adjusted in line with the range set out in the table. For example in the case of voluminous sample material such as wool, leaves, grasses etc., an initial material filling of 70 – 80 % is necessary.

The ball filling should comprise 60 % of the grinding jar volume for wet grinding with grinding balls < 3 mm. As with dry grinding, the sample material should fill one third of the grinding jar volume. Wet grinding should be conducted in such a way that the mixture of grinding balls, sample material and liquid achieves a viscous consistency. If the mixture is too viscous, the grinding balls do not move sufficiently. If it is not viscous enough, the grinding results will be poorer and there will be increased wear to the grinding balls and grinding jars.

Grinding jar size	Sample volume	Max. feed size	Dry grinding			
			Recommended number of grinding balls			
			Ø 5 mm	Ø 7 mm	Ø 10 mm	Ø 12 mm
1.5 ml	0.2–0.5 ml	1 mm	1 - 2	-	-	-
5 ml	0.5–2 ml	2 mm	5 - 6	1-2	1	-
10 ml	2–4 ml	4 mm	17 - 20	9 - 12	1 - 2	1 - 2
25 ml	4–10 ml	6 mm	35 - 40	16 - 20	5 - 6	2 - 4
35 ml	6-15 ml	6 mm	55 - 60	25 - 30	6 - 9	4 - 6
50 ml	8-20 ml	8 mm	80 - 90	45 - 50	12 - 14	6 - 8

Grinding jar size	Sample volume	Max. feed size	Dry grinding Recommended number of grinding balls		
			Ø 15 mm	Ø 20 mm	Ø 25 mm
1.5 ml	0.2–0.5 ml	1 mm	-	-	-
5 ml	0.5–2 ml	2 mm	-	-	-
10 ml	2–4 ml	4 mm	-	-	-
25 ml	4–10 ml	6 mm	1 - 2	-	-
35 ml	6-15 ml	6 mm	2 - 3	1	-
50 ml	8-20 ml	8 mm	3 - 4	1	1

The MM 400 allows the use of 1.5 ml / 2 ml / 5 ml reaction tubes.

Grinding jar size	Sample volume	Max. feed size	Dry grinding Recommended number of grinding balls Stainless steel or Zirconium oxide				Cell disruption of biological cells
			Ø 4 mm	Ø 5 mm	Ø 7 mm	Ø 10 mm	
1.5 ml	0.2–0.5 ml	<1 mm	2-4	-	-	-	Glass beads (0.1-0.25 mm/0.25-0.5 mm/0.75-1 mm/1-1.5 mm) Zirconium oxide grinding balls (< 3 mm) ~ 0.75 ml
2 ml	0.3-0.75 ml	<2 mm	3-6	2-4	1-2	-	~ 1 ml
5 ml	0.5–2 ml	<2 mm	12	-	-	-	~ 2.5 ml

6.4 Opening aid

Two opening aids are included in the scope of delivery of the MM 400.

Use the opening aids to close the grinding jars to ensure that they are firmly closed.

Place the opening aids on the two ends of a grinding jar and turn clockwise to close the grinding jar.

The opening aids can also be used in order to open the grinding jars more easily.

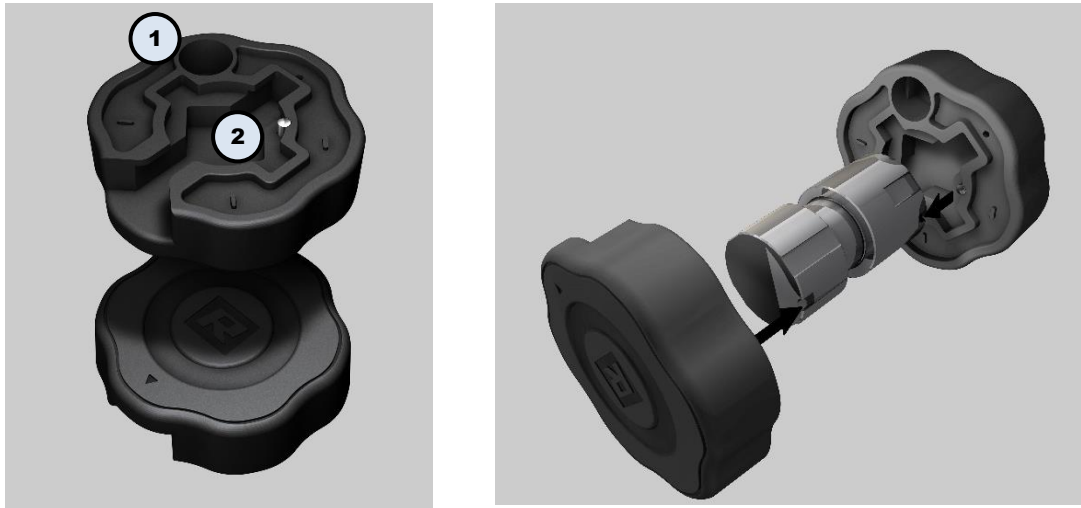

Fig. 12: Opening aids

The grinding jars listed below can be opened with the correspondingly marked shapes of the opening aid:

No.	
1	5 ml steel grinding jar for the adapter
2	Standard grinding jar

6.5 Preparing the grinding jar

NOTICE

N14.0011

Wear or damage to the grinding balls and grinding jars

Use of different materials

- Greater wear or damage is possible when operating the device with grinding balls and grinding jars whose individual components are made of different materials.
- **Only use grinding balls and grinding jars made of the same material.**

NOTICE

N15.0000

Damage to the grinding jars

Incorrect filling of the grinding jars

- The grinding balls damage the grinding jar and the device if the grinding jars are not filled with any material or with insufficient material.
- **Do not operate the device without material in the grinding jars.**
- **The filling in the grinding jars must not be less than 25 % of the grinding jar volume.**

6.5.1 Opening the grinding jar

CAUTION

C8.0024

Risks of burns and scalding

Hot grinding jar and/or sample material

- The sample material and grinding jar can get very hot during the grinding process.
- **After grinding, always wear protective gloves when handling the grinding jar.**
- **Never open hot grinding jars!**
- **Allow grinding jars to cool down to room temperature before opening them.**



WARNING

W7.0000

Risk of injury caused by liquid nitrogen

Use of liquid nitrogen during cryogenic grinding

- Liquid nitrogen has a boiling point of -196 °C and causes burn-like injuries and frostbite if there is skin and eye contact.
- **Take note of the liquid nitrogen safety data sheets.**
- **Always wear goggles and protective gloves when using liquid nitrogen.**



Fig. 13: Grinding jars and grinding balls

Open the grinding jar as follows:

- ⇒ Open the grinding bowl by turning the grinding jar lid.
- ① If the grinding jars (SP) cannot be opened, use the opening aids.

6.5.2 Filling the grinding jar

Fill the grinding bowl as follows:

- ⇒ Place grinding balls of a suitable material and the right number in the grinding jar.
- ⇒ Add sample for grinding to the grinding balls in the grinding chamber.

NOTE When filling the grinding jar, make sure that the volume does not fall below 1/4 of the total volume of the grinding jar. The optimum filling quantity of the grinding jar consists of 1/3 sample and 1/3 grinding balls, which corresponds to 2/3 of the total volume.

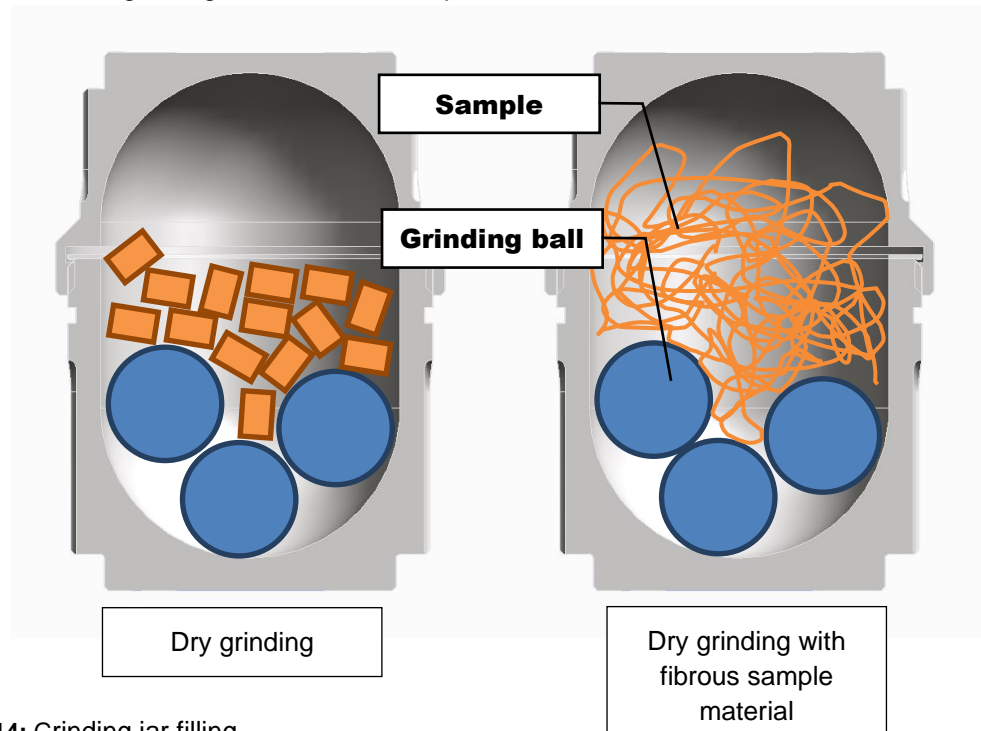

Fig. 14: Grinding jar filling

6.5.3 Closing the grinding jar

Close the grinding jar as follows:

- ⇒ Insert the grinding jar seal into the grinding jar lid. Make sure that all contact surfaces touching the seal are clean.
- ⇒ Check that the thread is free from foreign objects and clean where necessary.
- ⇒ Screw the grinding jar lid tightly onto the grinding jar.

NOTE If necessary, use the opening aid to seal the grinding jars tightly.

6.6 Inserting the Grinding Jar

NOTICE

N16.0067

Strong vibrations and loud noise

Uneven loading

- The device can generate particularly strong vibrations and loud noise if loaded unevenly.
- **Always insert two grinding jars of equal size, even if you only want to grind one sample. In this case leave the second grinding jar empty (no grinding balls, no sample material)!**
- **Switch the device off immediately if it is vibrating strongly and making a loud noise, and check the number, the gross weight and correct position of the grinding jars.**

NOTICE

N17.0011

Wear or damage to the grinding balls and grinding jars

Use of different materials

- Greater wear or damage is possible when operating the device with grinding balls and grinding jars whose individual components are made of different materials.
- **Only use grinding balls and grinding jars made of the same material.**

NOTICE

N18.0000

Damage to the device

Grinding jars incorrectly inserted

- In order to prevent damage to the device during grinding, the grinding jars must be correctly and firmly positioned in the guide of the grinding jar supports when inserted.
- **When inserting the grinding jars, ensure that the grinding jars do not become misaligned, but are positioned firmly and correctly in the grinding jar guide.**
- **Use the opening aid to clamp the grinding jars firmly in the grinding jar supports.**

6.6.1 Opening the grinding jar support

Open the grinding jar holder as follows:

⇒ Pull the locking pin (6) up out of the groove and turn it by about 60°. This releases the lock. If the locking pin cannot be moved, it is jammed. In this case, turn the locking wheel back and forth a little to loosen the locking pin.

⇒ Turn the locking wheel (7) on the grinding jar holder anti-clockwise until the maximum clamping range is available

⇒ Briefly tighten the locking wheel (7) clockwise, after which the locking pin can move freely again.

NOTE The locked locking bolt reliably prevents the grinding jar holder from opening automatically.

If the locking pin cannot be pulled upwards to release, then the release must not be forced with a hammer or similar tool. **Otherwise, the hardened locking pin may break off.**

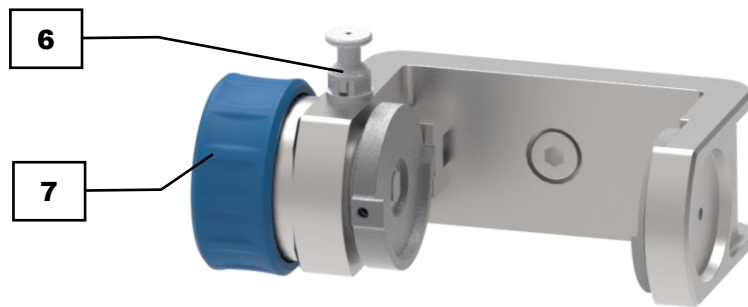

Fig. 15: Opening the grinding jar holder

6.6.2 Inserting the grinding jar

Insert the grinding jar into the grinding jar holder as follows:

- ⇒ Place the grinding jar from above into the open grinding jar holder and press lightly into the centering (8).
- ⇒ Turn the locking wheel (7) clockwise until the grinding jar is firmly seated in the grinding jar holder.
- ⇒ Turn the locking pin (6) by about 60° so that it engages in one of the grooves.
- ⇒ Now tighten the locking wheel (7) again. If the grinding jar is clamped, loosen it slightly in an anti-clockwise direction until the locking bolt (6) is firmly in place and cannot vibrate.

NOTE All grinding points must always be loaded. If fewer grinding jars are required, an empty grinding jar (without grinding balls, without material to be ground) or an adapter must be used as a counterweight. The grinding jar adapters are available as accessories (order number 03.018.0155).

Never operate the MM 400 **without a grinding jar or adapter!**



Abb. 16: Inserting the grinding jar

6.7 Grinding process

CAUTION

C9.0004

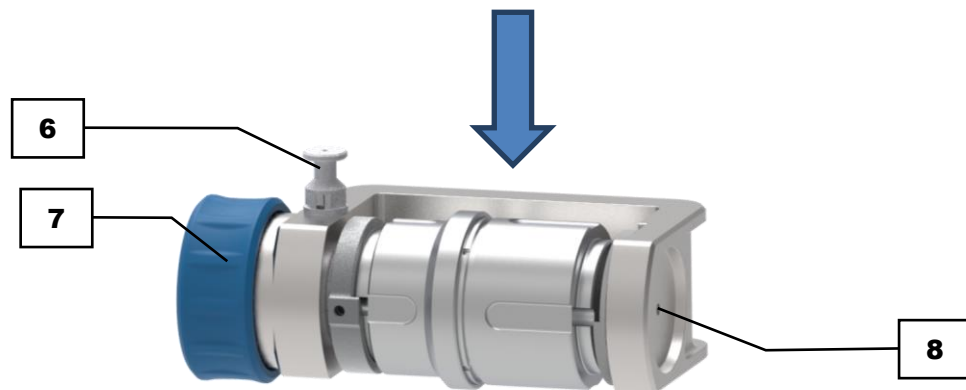
Risk of injury

Explosive or flammable samples

- Samples can explode or catch fire during the grinding process.
- **Do not use any samples in this device that carry a risk of explosion or fire.**
- **Take note of the safety data sheets for the sample material.**



CAUTION

C10.0006

Risk of injury

Sample material that is harmful to health

- Sample material that is harmful to health can injure people (illness, contamination).
- **Use suitable extraction systems with sample material that is harmful to health.**
- **Use suitable personal protective equipment with sample material that is harmful to health.**
- **Take note of the safety data sheets for the sample material.**



CAUTION

C11.0010

Risk of burns or poisoning

Varying sample properties

- The properties and therefore also the chemical reactivity of the sample can change during the grinding process and can cause burns or poisoning as a result.
- **Do not process any substances in this device whose chemical reactivity is so changed by grinding that there is a risk of explosion or poisoning.**
- **Take note of the safety data sheets for the sample material.**



WARNING

WB.0000

Risk of injury caused by liquid nitrogen

Use of liquid nitrogen during cryogenic grinding

- Liquid nitrogen has a boiling point of -196 °C and causes burn-like injuries and frostbite if there is skin and eye contact.
- **Take note of the liquid nitrogen safety data sheets.**
- **Always wear goggles and protective gloves when using liquid nitrogen.**

6.8 Starting the grinding process



Start the grinding process as follows:

NOTE The grinding process may only be started when the grinding points are evenly loaded. Otherwise, the device may be damaged.

⇒ Close the hood (1) carefully by hand.

NOTE The hood of the device is equipped with damping. The cushioning ensures that the hood of the device does not slam shut uncontrollably. The damping of the hood of the device takes effect from an opening angle of 20°.

⇒ Configure the parameters for grinding on the touch display (2) and with the rotary knob.

⇒ Press  on the touch display (2) to start the grinding process. If the touch display does not show , it is possible that the parameters for the grinding were not fully configured, or the hood of the device was not closed properly.

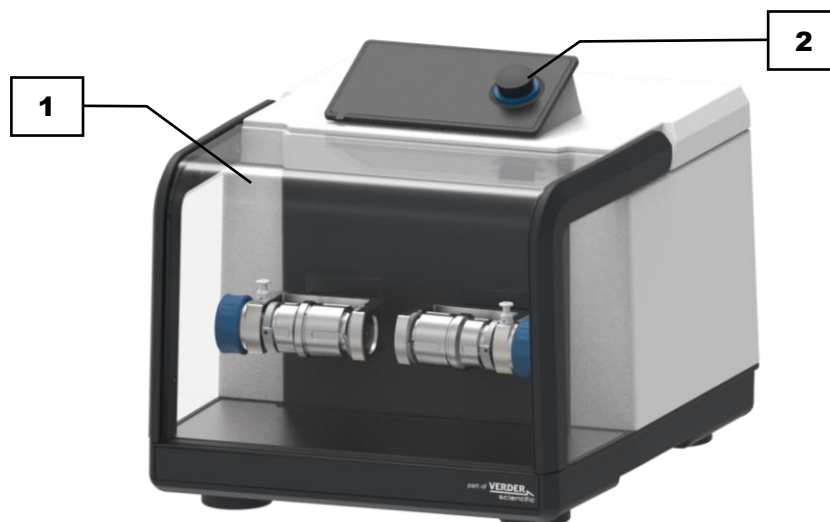

Fig.17: Starting the grinding process

6.9 Removing the sample material

⚠ CAUTION

Risks of burns and scalding

Hot grinding jar and/or sample material

- The sample material and grinding jar can get very hot during the grinding process.
- **After grinding, always wear protective gloves when handling the grinding jar.**
- **Never open hot grinding jars!**
- **Allow grinding jars to cool down to room temperature before opening them.**

C12.0024



NOTICE

N19.0007

Handling foodstuffs, pharmaceuticals and cosmetic products

Products processed

- Foodstuffs, pharmaceuticals and cosmetic products that have been processed on the device may no longer be eaten, used or put into circulation.
- **Dispose of these substances according to applicable directives.**

Remove the grinding jar and the material to be ground as follows:

⇒ Wait for the grinding process to finish.

⇒ Open the hood of the device (1).

⚠ ATTENTION The grinding jar and the grinding jar holder may have overheated during the grinding process and may be hot.

⇒ Pull the locking pin (6) up out of the groove and turn it by about 60°. This releases the lock. If the locking pin cannot be moved, it is jammed. In this case, turn the locking wheel back and forth a little to loosen the locking pin.

⇒ Turn the locking wheel (7) on the grinding bowl holder anti-clockwise until the maximum clamping range is available

⇒ Briefly tighten the locking wheel (7) clockwise, after which the locking pin can move freely again.

⇒ Remove the grinding jar by lifting it up and out of the grinding jar holder.

⇒ Open the grinding jar by turning the grinding jar lid. Use the opening aid if necessary.

⇒ Lift off the grinding jar lid. Keep the grinding jar upright, as the contents may fall out upon opening.

⇒ Remove the sample material from the grinding jar.

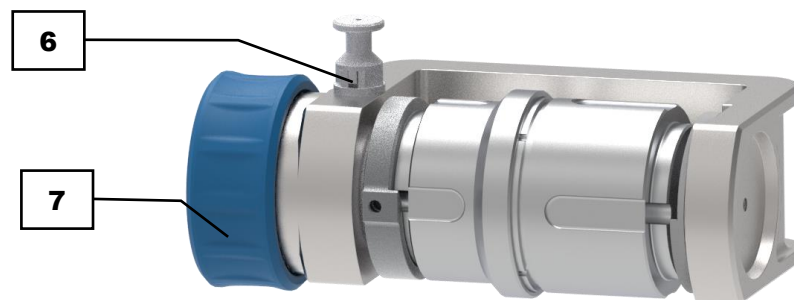

Fig. 18: Remove the grinding jar

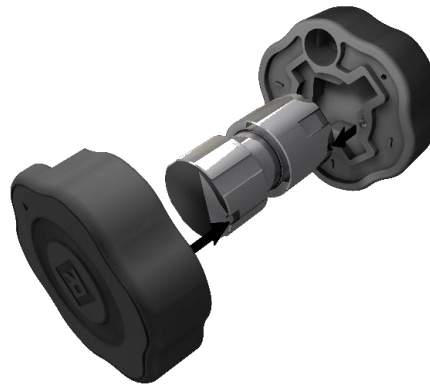

Fig. 19: Opening aid for opening the grinding jar

6.10 Special grinding methods

6.10.1 Cryogenic grinding

⚠ WARNING

W9.0000

Risk of injury caused by liquid nitrogen

Use of liquid nitrogen during cryogenic grinding

- Liquid nitrogen has a boiling point of -196 °C and causes burn-like injuries and frostbite if there is skin and eye contact.
- **Take note of the liquid nitrogen safety data sheets.**
- **Always wear goggles and protective gloves when using liquid nitrogen.**

⚠ WARNING

W10.0000

Risk of injury caused by liquid nitrogen and dry ice

Use of liquid nitrogen and dry ice in closed grinding jars

- Liquid nitrogen and dry ice expand and generate high pressure in closed receptacles. This high pressure bursts grinding jars and leads to serious injuries.
- **Under no circumstances should you put liquid nitrogen or dry ice into the grinding jar and then close the jar.**
- **Only undertake indirect embrittlement for cryogenic grinding.**

Materials that are difficult or impossible to grind at normal temperatures must be ground cold. Indirect pre-brittleness with liquid nitrogen (-196 °C) improves the fracture behavior of, for instance, thermoplastics, rubber products, fatty foods, pharmaceuticals, etc.

- ① For cold grinding, Retsch GmbH offers a cryokit for cooling the grinding jars with liquid nitrogen.

Perform a pre-embrittlement of elastic and tough sample material as follows:

- ⇒ Pre-embrittlement of sample material for grinding must be done indirectly.
- ① **Use only grinding balls and grinding jars made of stainless or hardened steel for cryogenic grinding with the cryokit. Grinding balls and grinding jars made of zirconium oxide or tungsten carbide are not suitable for direct contact with liquid nitrogen. The rapid cooling may cause cracks or fractures.**
- ⇒ For this purpose, the sample material must be filled into a grinding jar (steel) together with the grinding balls (steel) and the grinding jar (steel) must be tightly closed.
- ⇒ Subsequently, the tightly closed grinding jar (steel) with the grinding jar supports of the cryokit is immersed in a bath of liquid nitrogen until it stops bubbling.
- ⇒ Thus, the sample material inside the grinding jar (steel) is also chilled and ready for grinding.

⚠ WARNING Under no circumstances liquid nitrogen or dry ice should be filled into the grinding jar and then close it. The resulting overpressure in the grinding jar would burst it open.

6.10.2 Wet Grinding with Highly Flammable Materials

NOTICE

N20.0005

Damage to the device caused by liquids

Penetration of liquids into the interior of the device

- Mechanical and electronic components are damaged and the proper function of the device is no longer guaranteed.
- **Make sure that no liquids get into the interior of the device!**

Wet grinding using highly flammable materials is permitted with this device if certain precautionary measures are complied with.

When using highly flammable materials such as hexane, isopropyl, ethanol, benzene etc. as a grinding aid, the inside of the grinding jars should be classed as Zone 0, i.e. as a permanent explosive mixture.

It is therefore necessary to prevent potentially explosive vapours escaping from the clamped grinding jars during a grinding process or being able to reach places which have the necessary ignition energy. These vapours are in particular also pressed outwards by the temperature rise that takes place and by the consequent increase in pressure inside the grinding jar.

For this reason we urgently recommend that the user of the device (the employer) assesses the existing hazards within a coherent explosion protection concept according to local conditions before using such solvents and, where necessary, records supplementary organisational measures in an explosion protection document.

This approach is regulated in the EU under Articles 118 and 118a of EC Directive 89/391/EEC. Account must be taken of corresponding provisions in other countries outside the EU.

7 Device control

The device is controlled using the touchscreen in combination with the dial .

These control elements are used to configure parameter settings for grinding and to start, pause and end the grinding process.

Parameters for recurring grinding processes are configured, stored and selected as necessary in the program and cycle mode.

The system settings for the MM 400 are also selected from the main menu and can be changed where necessary.



Fig. 20: Touchscreen and dial

	Control element	Function
T	Touchscreen	Touchscreen for selecting the function elements.
DK	Dial	To configure the parameters for the grinding process, the program and cycle mode and the system settings.

- ① The dial lights up in blue when a function element whose value can be changed by the dial is selected on the touchscreen. The section containing the function element is additionally highlighted in grey.

7.1 Menu interface on the touchscreen

The menu interface on the touchscreen is divided into the following areas:









Fig. 21: Menu interface of the touchscreen









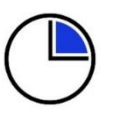



	Area	Function
NB	Navigation area	The following menu views can be selected from the navigation area: <ul style="list-style-type: none"> • Main menu • Program mode • Cycle program mode • System settings
P	Parameter settings	The following parameters for grinding are configured in this area: <ul style="list-style-type: none"> • Vibration frequency • Grinding time • Cycles (sequence of parameter sets with different parameters)
	Parameter displays	The following parameters are displayed in this area once the grinding process has started: <ul style="list-style-type: none"> • Vibration frequency configured • Remaining grinding time • Total duration and progress of the cycle program
B	Scroll bar	Indicates the position of the menu.
GS	Control	The device is directly controlled by the function elements in this area. <ul style="list-style-type: none"> • Start, pause and cancel the grinding process • Select, edit, save, delete and start the program • Select, edit, save, delete and start the selected cycle program







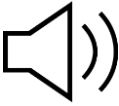

7.2 Function elements

Functional elements are selected on the touch display and configured with the rotary knob.

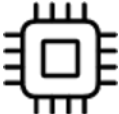
- ① Only the functional elements that can currently be selected and configured are displayed or active. The background of the rotary knob lights up blue when an editable value is selected.

Element	Description	Function
	Main menu	Calling up the main menu. The parameters for the grinding process can be configured and the grinding process started via the main menu.
	Opening the hood of the device	After switching on the device, the request to open and close the hood of the device appears on the touch display. ① The device is ready for operation by opening and closing the hood of the device once.
	System settings	Goes to system settings.
	Programme mode	Access to programme mode.
	Gallery view	Goes to gallery view. The saved programmes are displayed and can be selected directly.
	Vibration frequency	Vibration frequency for configuration of the grinding process.
	Grinding time	Grinding time for configuring the grinding process.

Element	Description	Function
	Cycle programme mode	Access to cycle programme mode.
	Edit programme and cycle programme	This allows you to create new programmes and cycle programmes and edit saved programmes and cycle programmes.
	Delete programme and cycle programme	Deletes a created programme or a cycle programme.
	Save programme / cycle programme	Saves a created programme or a cycle programme.
	Cancel	Cancel entry / return to previous menu.
	Start	Start grinding process.
	Pause	Pause grinding process.
	Continue	Continue grinding process after break.
	Stop	Stop grinding process.
	Grinding process completed successfully	The grinding process was completed successfully after the set time elapsed.
	Repeat cycle programme	Number of cycles in cycle programme mode.
	Total running time	Remaining grinding time until the grinding process is complete.
	MyRetsch	Displays a QR code to access the web portal.

	Beeper (on/off)	Setting the beeper (on/off).
	Brightness	Setting the display brightness.
	Calendar	Setting the date and time.
	Software version	Displays the installed software.
	Running time	Displays the previous running time.
	Serial number	Displays the device serial number.
	Service area	Information on the device and the software.
	Service and connection information	Information on the service.
	Software update	Software update of the device via a USB data medium.
	Calibration	Information on calibration

7.3 Menu navigation

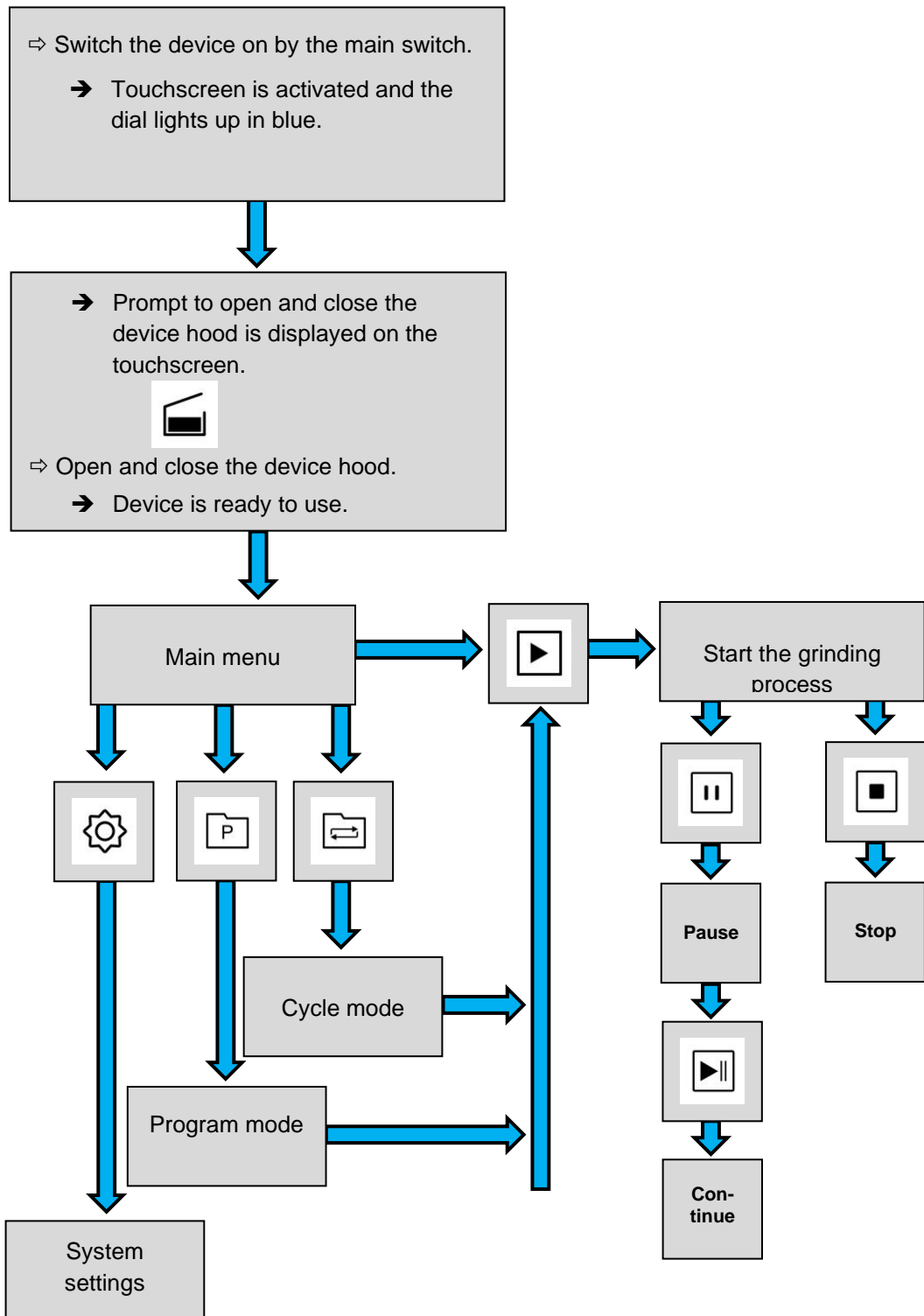

Fig. 22: Diagram of the menu navigation

7.4 Main menu

Additional menu views can be called up via the main menu, parameters for the grinding process can be configured and grinding can be started.

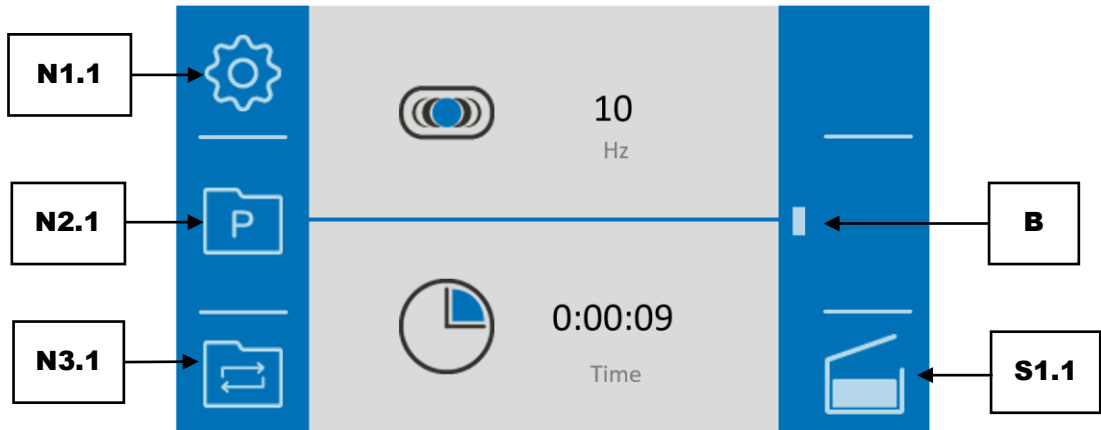

Fig. 23: Main menu after switching on the device

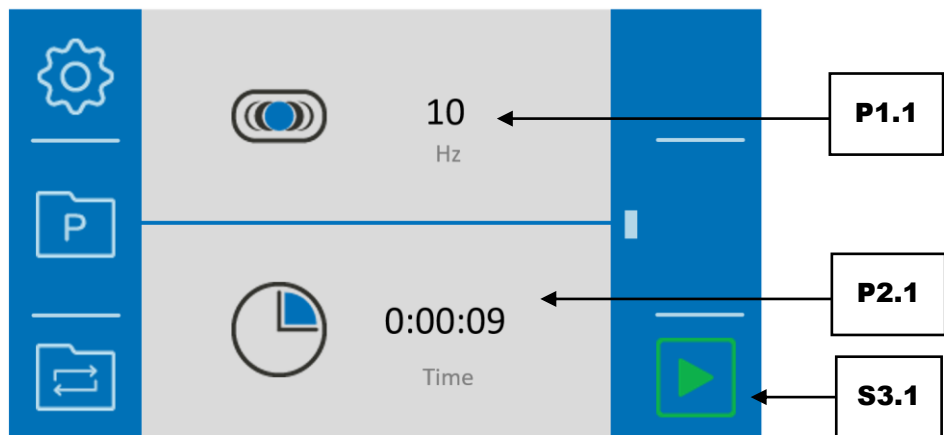

Fig. 24: Menu view before starting the grinding process

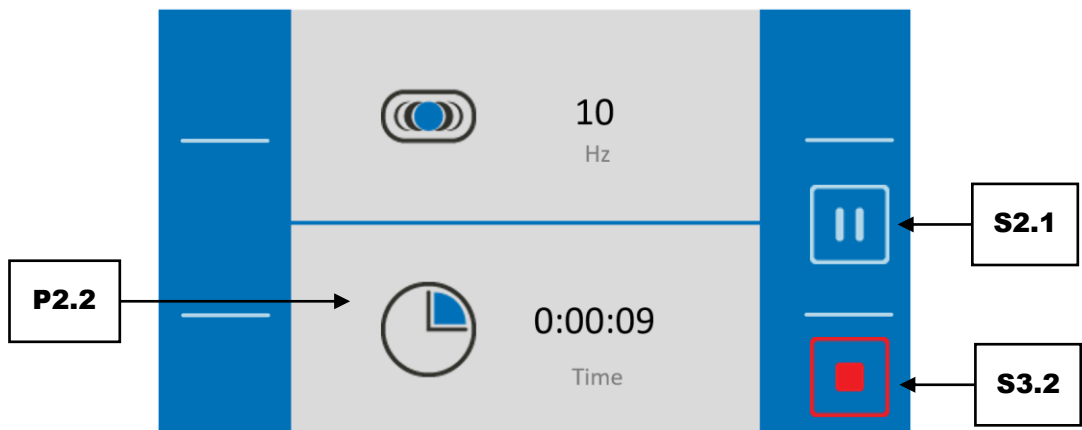





Fig. 25: Menu view during the grinding process



	Element	Function
N1.1	System settings	Goes to system settings.
N2.1	Programme mode	Access to programme mode.
N3.1	Cycle programme mode	Access to cycle programme mode.
P1.1	Vibration frequency	After making a selection with the touch display, the rotary knob can be used to set the vibration frequency from 3 - 30Hz.
P2.1	Grinding time	After making a selection with the touch display, the grinding time can be set from 10 seconds to 8 hours using the rotary knob.
P2.2	Remaining grinding time	Shows the remaining grinding time of the current grinding process.
B	Scroll bar	Indicator for the position of the menu.
S1.1	Closing the housing cover	Before starting the grinding process, the housing cover must be opened once to insert the grinding jars. If the housing cover is then closed again, the element disappears.
S2.1	Pause grinding process	Stops the grinding process. By pressing again, the grinding process is continued.
S3.1	Start grinding process	Starts the grinding process.
S3.2	Stop grinding process	Stops the grinding process.

7.5 Controlling the grinding process





The grinding process can be controlled from the main menu, from the program and the cycle mode using the function elements.

-  Start grinding process
-  Pause grinding process
-  Continue grinding process after a pause
-  Stop grinding process





7.5.1 Starting the grinding process

- ⇒ Press  to start the grinding.
- ⇒ After starting, the start sign  changes to the stop sign .

7.5.2 Pausing the grinding process

- ⇒ Press  to pause the grinding.
- ⇒ After pausing, the pause sign  changes to the continue sign .
- ⇒ Press  to continue the grinding process after a pause.

7.5.3 Stopping the grinding process

- ⇒ Press the character  in order to pause the grinding.
- ⇒ The pause character  changes to the continue character .
- ⇒ Press  in order to continue the grinding process.

7.5.4 Grinding process successfully completed

The grinding process is automatically stopped once a specified grinding time has elapsed.

When the grinding process has been successfully completed,  is displayed.

- ⇒ Press  to acknowledge that the grinding process has been successfully completed.

7.6 Program mode

Press the button  (N2.1) in the main menu to switch to programme mode. The display changes to the current programme.

In programme mode, programmes may be selected, edited, saved, deleted and started.

If sample materials are often ground with the same parameters, these parameters can be stored in the programme pre-sets and called up as Standard Operating Procedures (SOP) where required.

Up to twelve programme pre-sets are available.

The following parameters can be saved in the individual programmes:

- Vibration frequency
- Grinding time

- ⓘ When starting grinding via a programme, the grinding parameters cannot be changed during the grinding process.

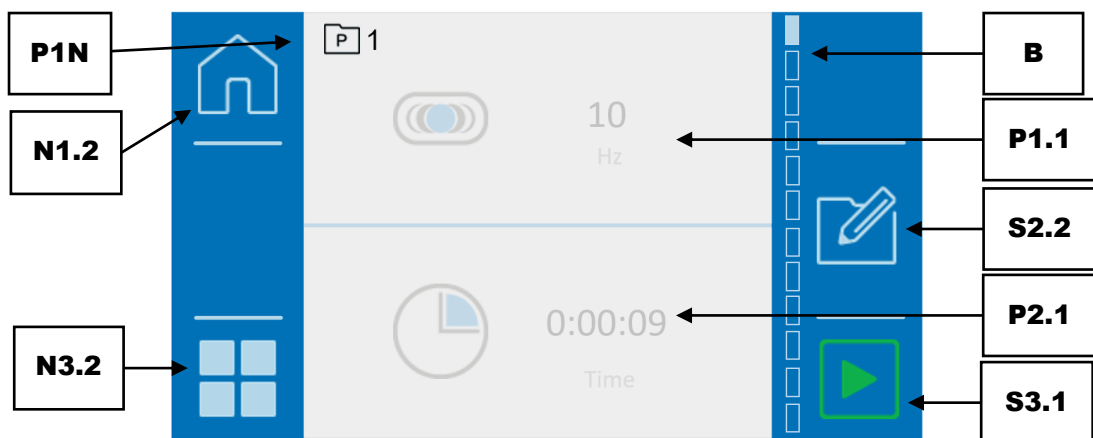

Fig. 26: Programme mode

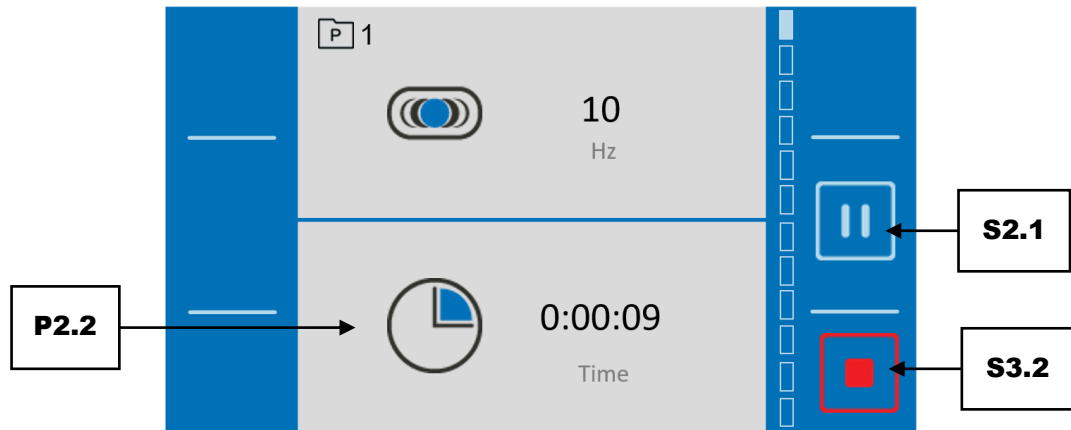

Fig. 27: Programme mode after starting the grinding process

	Element	Function
N1.2	Main menu	Opening the main menu.
N3.2	Gallery view	Opens the gallery view for the programmes or the available programme presets.
P1N	Programme number	Number of the selected programme.
P1.1	Vibration frequency	After selection with the touch display, the rotary knob can be used to set the vibration frequency from 3 - 30Hz (invalid values are displayed in red text).
P2.1	Grinding time	After selection with the touch display, the grinding time can be set from 10 seconds to 8 hours with the rotary knob (invalid values are displayed in red text).
P2.2	Remaining grinding time	Shows the remaining grinding time for the current grinding process.
B	Scrollbar	Indicator for the position of the menu.
S2.1	Pause grinding process	Stops the grinding process. By pressing again, the grinding process is continued.
S2.2	Editor mode	Opens the programme editor.
S3.1	Start grinding process	Starts the grinding process (this button is only visible after setting valid parameters).
S3.2	Stop grinding process	Stops the grinding process.

7.6.1 Select a Program

In the programme mode, programmes with preset parameters for the grinding process can be selected. To select a programme, press the button (N2.1) in the main menu. The respective programme number is displayed next to the symbol (P1N). After starting the device, the programme view always opens with programme 1 in the individual view.

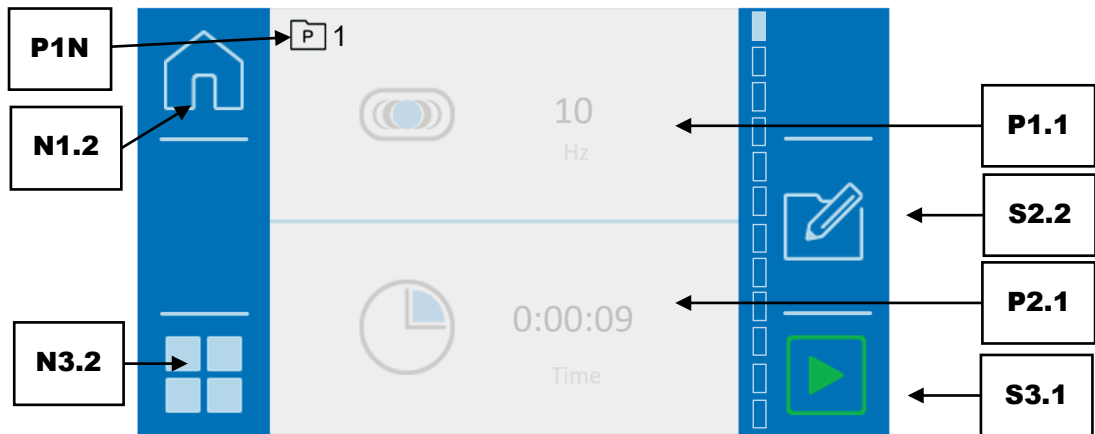

Fig. 28: Programme mode

- ① You can change the programme by swiping up or down on the touch display. The scroll bar (B) gives a visual overview of the position within the programmes.

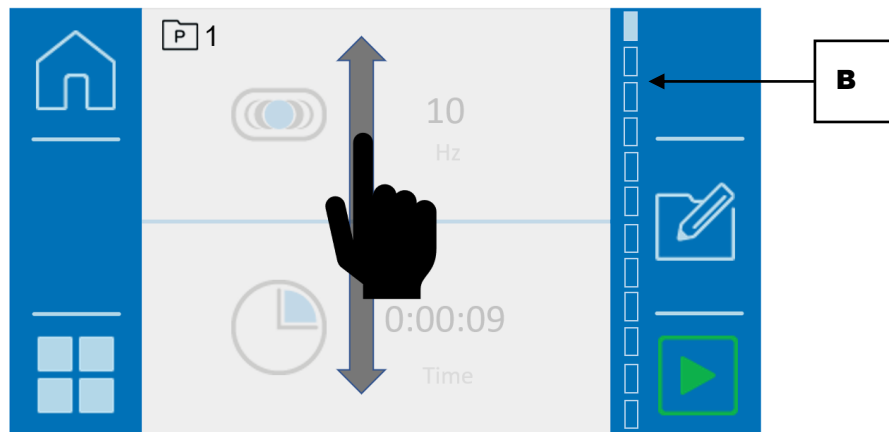



Fig. 29: Programme view

Alternatively, you can use the button  (N3.2) to switch to the gallery view. Now four programmes will always be displayed with the set parameters.

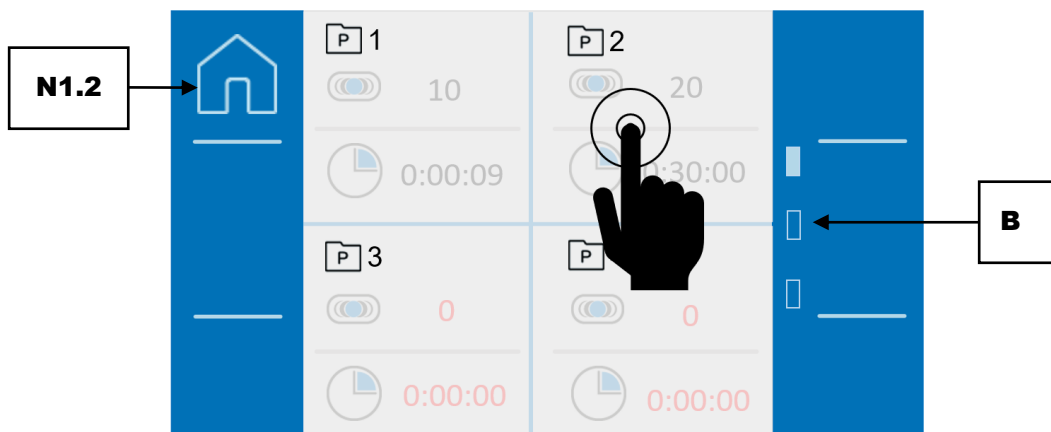

Fig. 30: Gallery view

- ⇒ Swipe across the display to switch between programme groups 1 to 4, 5 to 8 and 9 to 12. The scroll bar (B) gives you a visual overview of your position within the gallery view.

⇒ To activate a programme, tap on the desired programme section.

	Element	Function
N1.2	Main menu	Opening the main menu.
N3.2	Gallery view	Opens the gallery view for the programmes or the available programme presets.
P1N	Programme number	Number of the selected programme.
P1.1	Vibration frequency	After selection with the touch display, the rotary knob can be used to set the vibration frequency from 3 - 30Hz.
P2.1	Grinding time	After selection with the touch display, the grinding time can be set from 10 seconds to 8 hours with the rotary knob.
B	Scrollbar	Indicator for the position of the menu.
S2.2	Editor mode	Opens the programme editor.
S3.1	Start grinding process	Starts the grinding process.

⇒ To exit the programme mode and return to the main menu, press (N1.2).

7.6.2 Edit a Program

In programme mode, open the programme editor by pressing the button (S2.2).

In the programme editor, programmes can be created, edited, saved and deleted.

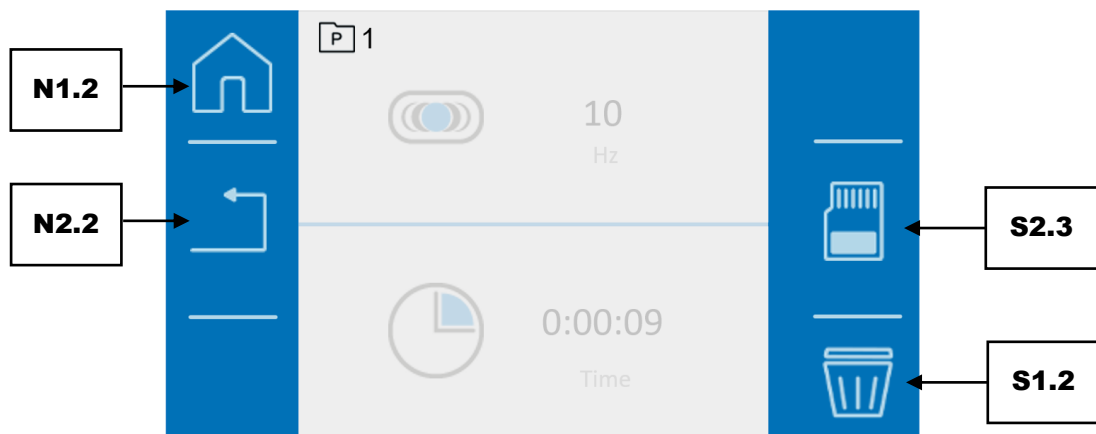



Fig. 31: Programme editor

	Element	Function
N1.2	Main menu	Opening the main menu.
N2.2	Cancel	Cancels the current operation and returns to the parent menu.
S1.2	Delete	Deletes all parameters of the programme.
S2.3	Save	Saves the programme.

① Editing can be cancelled by pressing the button (N2.2).
All settings made are then discarded.



- ⇒ Press the parameter to be edited.
- ⇒ Turn the rotary knob until the desired value is displayed.
- ⇒ Press the parameter again or select another parameter so that the set value is accepted.
- ⇒ Press  (S2.3) to save the set parameters.

7.6.3 Save a Programme

Proceed as follows to save the configured parameters in a program preset:

- ⇒ Press  to save the configured parameters in the selected program preset.

7.6.4 Delete a Programme

- ⇒ To delete all parameters of a programme, tap on the  button (S1.2).
- ⇒ Confirm the deletion by tapping on the  button (S2.2).
- ⇒ Abort with the  button (N2.2).

7.7 Cycle programme mode

Press the  button in the main menu to switch to cycle programme mode. After switch-on, the display changes to cycle programme 1; otherwise to the last used cycle programme.

In the cycle programme mode, cycle programmes may be selected, edited, saved, deleted and started.

If sample materials are frequently ground with the same parameters, these parameters can be saved in the presets for the cycle programmes and called up as Standard Operating Procedures (SOP) where required.

Up to six presets are available for the cycle programmes.

The following parameters can be saved in the individual cycle programmes:

- Vibration frequency
- Grinding time
- Cycles (repetitions of grinding time and vibration frequency)

A cycle includes two sets of parameters (A and B). The vibration frequency and grinding time can be freely selected for each parameter set. The complete cycle programme consists of the two sets of parameters (A and B) and the set repetitions.

- ① When starting grinding via a cycle programme, the grinding parameters cannot be changed during the grinding process.

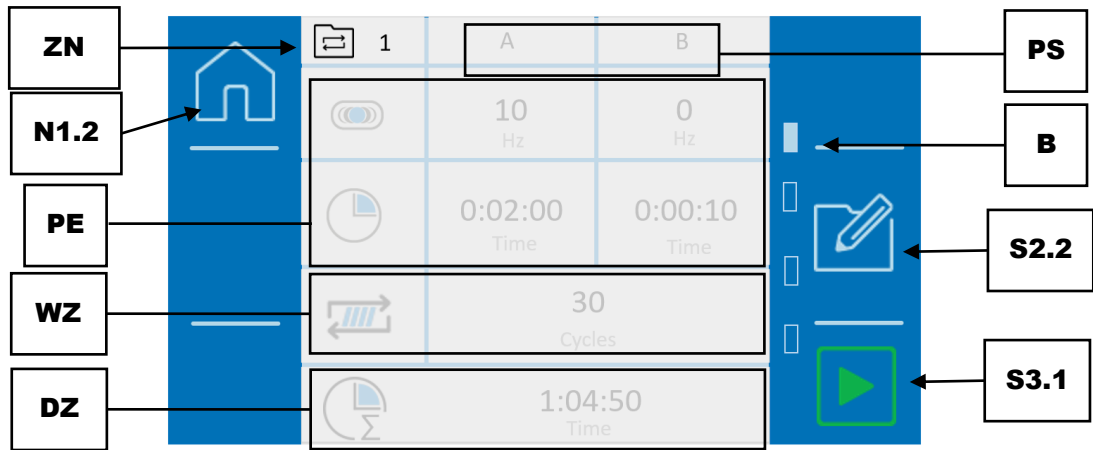

Fig. 32: Cycle programme mode

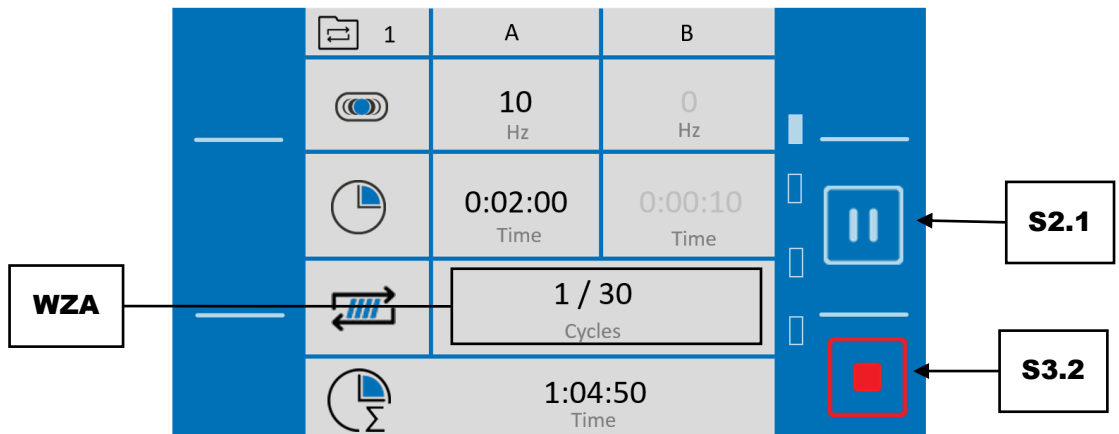



Fig.33: Cycle programme mode after starting the grinding process

	Element	Function
N1.2	Main menu	Opening the main menu.
ZN	Cycle programme number	Displays the number of the current cycle programme.
PS	Parameter sets (A/B)	A cycle is divided into parameter sets A and B.
PE	Parameter settings	Displays the parameters of the active cycle (vibration frequency or grinding time)
WZ	Repetitions cycle	Displays the number of times the configured cycle is repeated until the grinding process is complete.
WZA	Repetitions cycle current	After the grinding process has started, the current cycle status is displayed here
B	Scrollbar	Indicates the cycle position
DZ	Total cycle programme time	Shows the total duration of the cycle programme until the grinding process is completed (the total duration consists of the two parameter sets (A/B) and the repetitions). ⓘThe total duration of a cycle programme is limited to 99 hours.
S2.1	Pause cycle programme	This pauses the current cycle programme.
S2.2	Editor mode	Opens the editor for cycle programmes.
S3.1	Start cycle programme	Starts the grinding process or the cycle programme
S3.2	Stop cycle programme	Stops the current cycle programme

7.7.1 Selecting the cycle programme

In the cycle programme mode, cycle programmes with preset parameters for the grinding process can be selected. To select a cycle programme, press the  button on the main menu. The respective number of the cycle programme is displayed next to the  symbol.

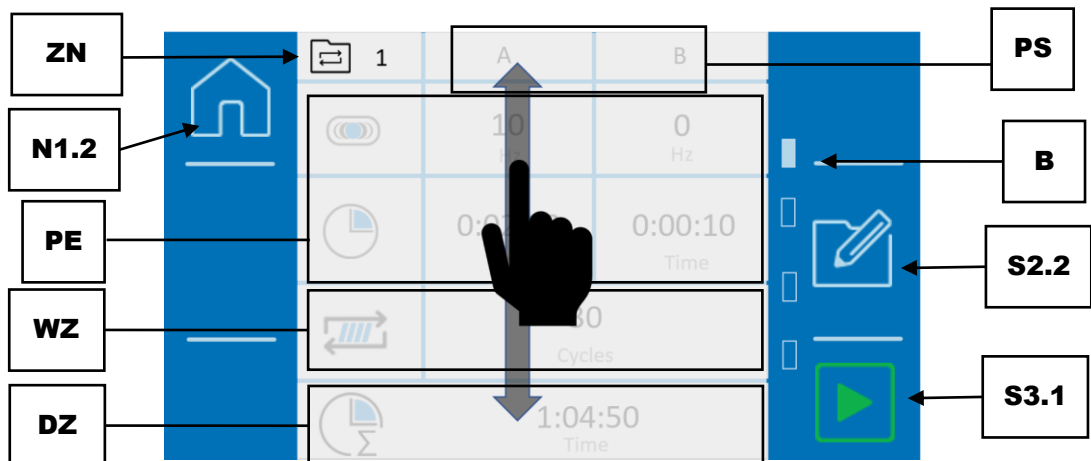

Fig. 34: Selecting a cycle

	Element	Function
N1.2	Main menu	Opening the main menu
ZN	Cycle programme number	Displays the number of the current cycle programme
PS	Parameter sets (A/B)	A cycle is divided into parameter sets A and B
PE	Parameter settings	Displays the parameters of the active cycle (vibration frequency or grinding time)
WZ	Repetitions cycle	Displays the number of times the configured cycle is repeated until the grinding process is complete
B	Scrollbar	Indicator for the position of the cycle programme
DZ	Total cycle programme time	Shows the total duration of the cycle programme until the grinding process is completed (the total duration consists of the two parameter sets (A/B) and the repetitions). ⓘ The total duration of a cycle programme is limited to 99 hours.
S2.2	Editor mode	Opens the editor of the cycle programme
S3.1	Start cycle programme	Starts the grinding process or the cycle programme

- ⇒ Swipe from right to left or from left to right across the display to navigate through the cycle programmes. The position of the cycle programme is shown in the scrollbar.
- ⇒ Press to start the selected cycle programme and grinding process.
- ⇒ To exit the cycle programme mode and return to the main menu, press .

7.7.2 Editing the cycle programme

Cycle programmes can be created, edited, saved and deleted in the cycle programme editor.

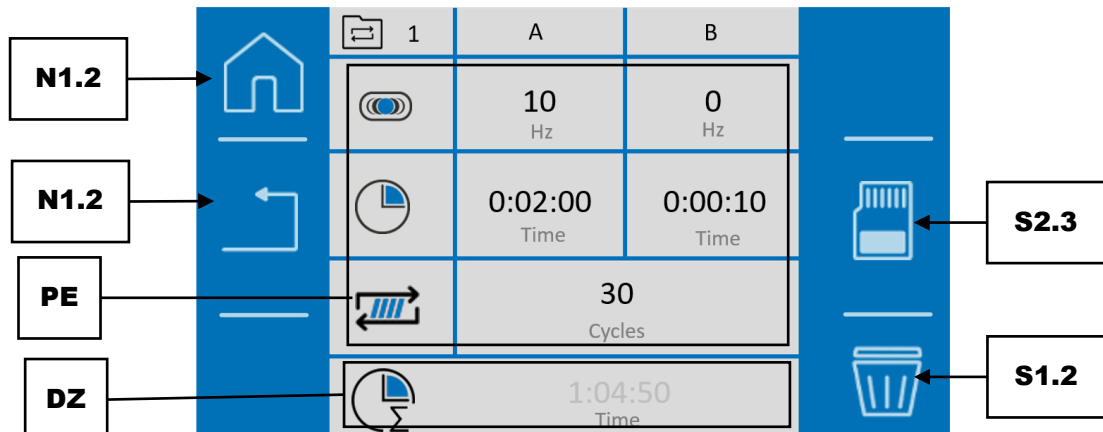



Fig. 35: Editor for the cycle programme

	Element	Function
N1.2	Main menu	Opens the main menu.
N2.2	Cancel	Cancels the current operation and returns to the parent menu.
PE	Parameter settings	Displays the parameters configured for the active cycle programme.
DZ	Total cycle programme duration	Displays the total duration of the cycle programme (the total duration is made up of the two parameter sets (A/B) and the repetitions). ⓘ The total duration of a cycle program is limited to 99 hours.
S1.2	Delete	Deletes all parameters of the cycle programme.
S2.3	Save	Saves the cycle programme.

⇒ Press  (S2.2) in the cycle programme mode to call up the cycle programme editor and edit the activated cycle programme.

ⓘ The total duration of a cycle programme must not exceed 99 hours. A total duration of more than 99 hours cannot be saved and will be marked in red.

The process can be cancelled by pressing the button  (N1.2).
All settings made are then discarded.

ⓘ In the cycle programme mode, the parameters can only be changed if processing is activated via the button (S2.2).

- ⇒ Press on the parameter to be edited.
- ⇒ Turn the rotary knob until the desired value is displayed.
- ⇒ Press the parameter again or select another parameter so that the set value is accepted.

7.7.3 Saving the cycle programme

⇒ Press  to save the set parameters in the selected cycle preset.

7.7.4 Deleting the cycle programme

⇒ Tap the button  (S1.2) in order to delete all parameters of a cycle programme.

⇒ Confirm the deletion by tapping the button  (S2.2).

⇒ The process will be cancelled by pressing the button  (N2.2).

7.8 System settings

System settings can be accessed from the main menu.

- ⇒ Press .
- ⇒ Then press on the desired section to view or configure the settings.

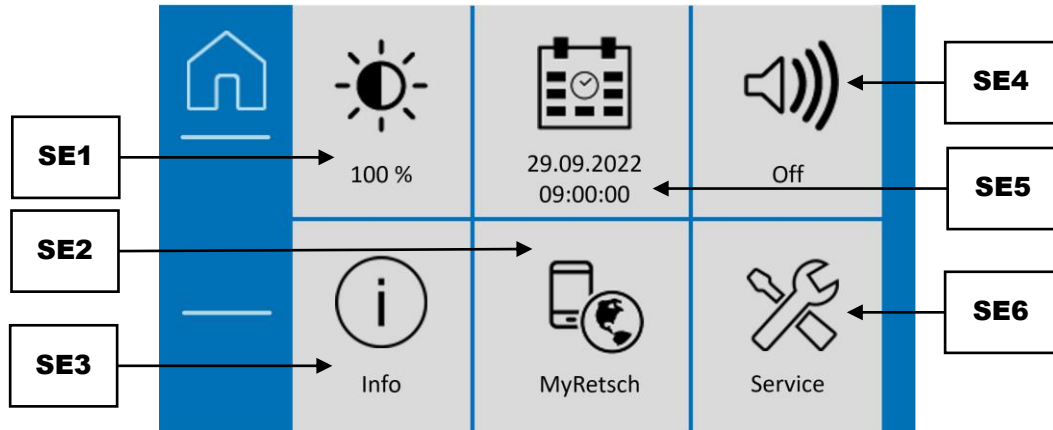

Fig. 36: System settings

	Element	Function
SE1	Brightness	Display and setting of the display brightness.
SE2	„MyRetsch“	Display of the QR code for the device. This leads to the MyRetsch Web Portal.
SE3	Info	Display of device-specific information: software version, operating hours, serial number.
SE4	Beeper (on/off)	Display and switching the beeper on and off (sound on/off).
SE5	Date and time	Display and setting of date and time.
SE6	Service area	Information on the service.

7.8.1 Brightness

Proceed as follows to adjust the brightness level on the touchscreen:

- ⇒ Press the section.
- ⇒ Turn the dial until the desired level of brightness has been reached on the display.
- ⇒ The set value will be accepted as soon as you press this section again or on another section, or as soon as you exit system settings.

7.8.2 MyRetsch

This section allows access to the web portal of the Retsch GmbH via a QR code. This can be read using a smartphone with the appropriate software and an internet connection. Additional information, such as tips and tricks and an application database may be accessed.

- ⇒ Press this section to display the QR code.

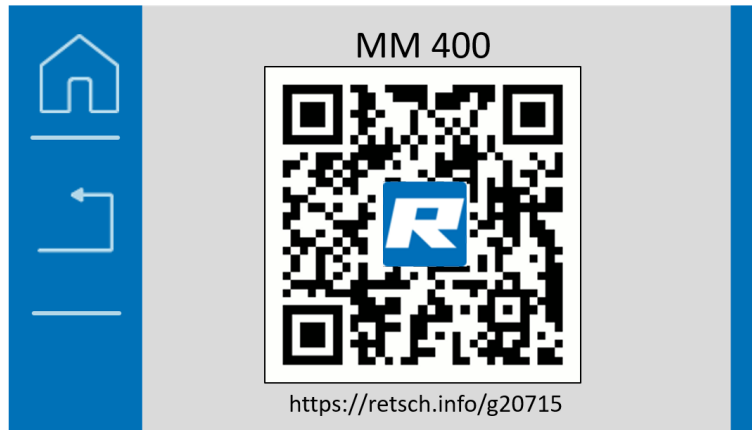

Fig. 37: QR code

7.8.3 Device information

The following device information can be viewed in this section:

- Firmware (device control)
- Display (programme control)
- Operating hours (hh:mm:ss)
- Serial number

① The current software versions are listed one after the other, with the firmware listed first.

① The counted operating hours reflect the processing time of the device, i.e. the sum of the times between the start and stop of a grind. The time cannot be manipulated.

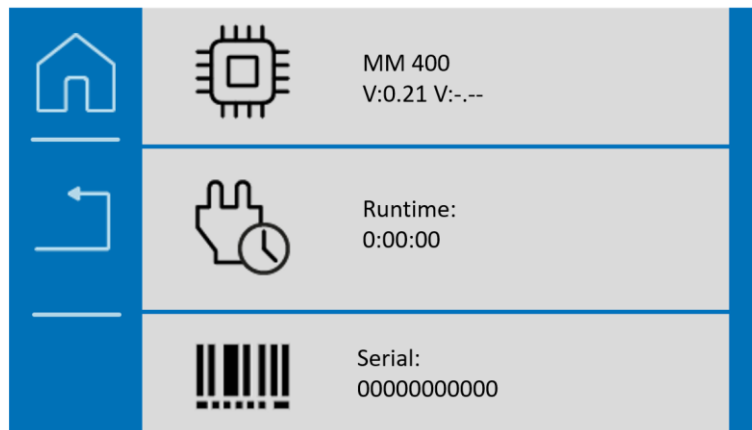

Fig. 38: Device information

7.8.4 Signalling device

The signalling device on the device can be switched on or off using this section. The signalling device generates an acoustic signal as soon as a grinding process finishes.

7.8.5 Date and time

Proceed as follows to adjust the date and time:

- ⇒ Press the section.
- ⇒ Select the desired settings using the dial.
- ⇒ The set values will be accepted as soon as you press this section again or on another section, or as soon as you exit system settings.

7.8.6 Service Environment

In this section, the following information can be viewed:

- Service and connection information
- Software update
- Calibration

①The connection information contains relevant information for the service technicians of the Retsch GmbH.

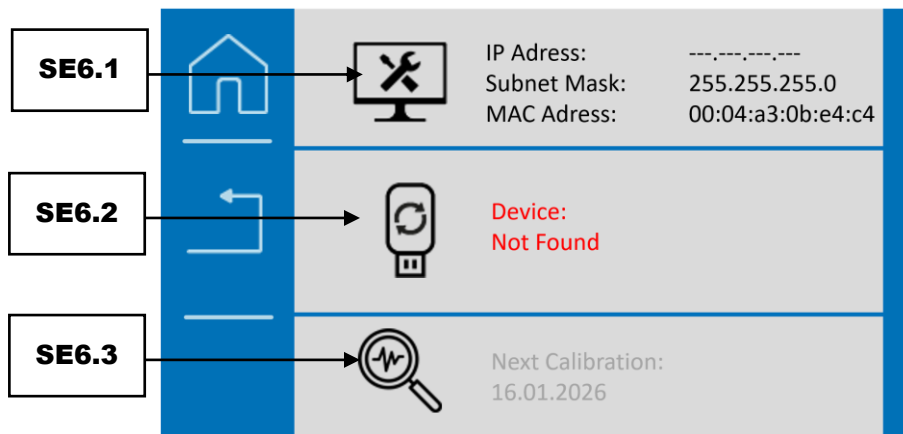

Fig.39: Device information

	Element	Function
SE6.1	Service and connection information	Information for the service department.
SE6.2	Software updates	Software update of the device via a USB data medium.
SE6.3	Calibration	Information on calibrating the device.

7.8.6.1 Software update

To update the software, proceed as follows:

- ⇒ Insert the USB data medium into the USB interface.
- ⇒ Press the icon to carry out the update.
- ⇒ Wait for the transfer and installation to complete.
- ①The background of the rotary knob flashes blue until the touch display has restarted. This may take a few seconds.

①A suitable USB data carrier must be connected to the USB interface.

- The USB data medium must be formatted in the FAT32 file system.

- USB 3.0 media are not supported.
- Only the software to be installed may be located in the main directory. The device automatically recognises the new software.



7.8.6.2 Calibration





As an additional service, Retsch GmbH offers the calibration of the software parameters 'frequency' and 'time' upon request. To do this, contact the Retsch GmbH service department.

8 Error Messages and Information Notes

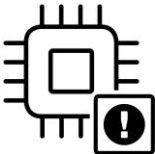
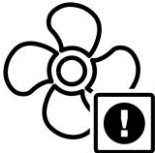
8.1 Error Messages

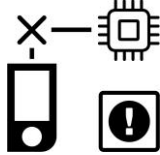
Error messages inform the user about detected device or programme errors. In the event of an error message, a fault has occurred, in which the operation of the device or the programme is automatically interrupted. Such faults must be resolved before next startup.

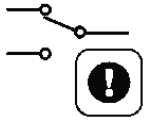
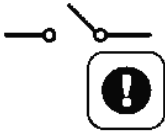
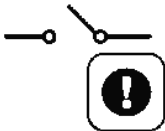
Error code	Description	Measures
<p>E10</p> 	Overload	<p>The drive can withstand brief overloads. In the event of prolonged overload, self-protection is activated.</p> <p>This can happen in particular with high loads (heavy grinding jars, hard samples, large balls, high frequency).</p> <ul style="list-style-type: none"> • Check, whether the load on the machine is too high. • Check, whether there are any foreign objects in the interior. • Check, whether the rockers can be moved easily by hand. • Check, if the grinding process can be run at a reduced frequency. • Turn off the main switch and wait 30 seconds before turning the device on again. • If the error persists, contact the Retsch GmbH service department.
<p>E13</p> 	Drive overheated	<ul style="list-style-type: none"> • Turn off the main switch and wait 30 seconds before turning the device on again. • Allow the engine to cool before restarting. • If the error persists, contact the Retsch GmbH service department.
<p>E20</p> 	Control error	<ul style="list-style-type: none"> • Turn off the main switch and wait 30 seconds before turning the device on again. • If the error persists, contact the Retsch GmbH service department.
<p>E23</p> 	Fan error	<p>The fan is blocked and does not run.</p> <ul style="list-style-type: none"> • Check, whether the fan is blocked by a foreign object. • Turn off the main switch and wait 30 seconds before turning the device on again. • If none of the above causes can be identified, contact the Retsch GmbH service department.

Error code	Description	Measures
<p data-bbox="389 248 437 275">E25</p> 	<p data-bbox="536 248 691 275">Display error</p>	<p data-bbox="879 248 1401 275">The connection to the display is interrupted.</p> <ul data-bbox="927 297 1417 465" style="list-style-type: none"> <li data-bbox="927 297 1417 394">• Turn off the main switch and wait 30 seconds before turning the device on again. <li data-bbox="927 405 1417 465">• If the error persists, contact the Retsch GmbH service department.
<p data-bbox="389 486 437 512">E41</p> 	<p data-bbox="536 486 770 512">Speed sensor error</p>	<p data-bbox="879 486 1425 546">The target and actual speed of the drive differ from each other.</p> <ul data-bbox="927 568 1417 736" style="list-style-type: none"> <li data-bbox="927 568 1417 665">• Turn off the main switch and wait 30 seconds before turning the device on again. <li data-bbox="927 676 1417 736">• If the error persists, contact the Retsch GmbH service department.
<p data-bbox="389 752 437 779">E50</p> 	<p data-bbox="536 752 754 779">Safety circuit error</p>	<p data-bbox="879 752 1337 779">A safety function has been interrupted.</p> <ul data-bbox="927 801 1417 969" style="list-style-type: none"> <li data-bbox="927 801 1417 898">• Turn off the main switch and wait 30 seconds before turning the device on again. <li data-bbox="927 909 1417 969">• If the error persists, contact the Retsch GmbH service department.
<p data-bbox="389 983 437 1010">E51</p> 	<p data-bbox="536 983 759 1043">Error safety switch (interlock)</p>	<p data-bbox="879 983 1409 1043">The opening status of the hood of the device is not correctly detected by the switches.</p> <ul data-bbox="927 1066 1417 1234" style="list-style-type: none"> <li data-bbox="927 1066 1417 1162">• Turn off the main switch and wait 30 seconds before turning the device on again. <li data-bbox="927 1173 1417 1234">• If the error persists, contact the Retsch GmbH service department.
<p data-bbox="389 1249 437 1276">E52</p> 	<p data-bbox="536 1249 751 1276">Hood switch error</p>	<p data-bbox="879 1249 1294 1276">Faulty state of the left hood switch.</p> <ul data-bbox="927 1299 1417 1467" style="list-style-type: none"> <li data-bbox="927 1299 1417 1395">• Turn off the main switch and wait 30 seconds before turning the device on again. <li data-bbox="927 1406 1417 1467">• If the error persists, contact the Retsch GmbH service department.
<p data-bbox="389 1480 437 1507">E53</p> 	<p data-bbox="536 1480 751 1507">Hood switch error</p>	<p data-bbox="879 1480 1310 1507">Faulty state of the right hood switch.</p> <ul data-bbox="927 1529 1417 1697" style="list-style-type: none"> <li data-bbox="927 1529 1417 1626">• Turn off the main switch and wait 30 seconds before turning the device on again. <li data-bbox="927 1637 1417 1697">• If the error persists, contact the Retsch GmbH service department.
<p data-bbox="389 1711 437 1738">E88</p> 	<p data-bbox="536 1711 643 1738">Net error</p>	<p data-bbox="879 1711 1214 1738">There is a voltage deviation.</p> <ul data-bbox="927 1760 1417 1928" style="list-style-type: none"> <li data-bbox="927 1760 1417 1856">• Turn off the main switch and wait 30 seconds before turning the device on again. <li data-bbox="927 1868 1417 1928">• If the error persists, contact the Retsch GmbH service department.

9 Installing additional equipment

Retsch's additional equipment ensures that the mixer mill MM 400 can be flexibly adapted to different working conditions.

The following additional equipment is available for Retsch's mixer mill MM 400:

- Adapter for conical centrifuge tubes
- Adapter for 30 ml wide mouth bottles
- Adapter for 4 x 5 ml steel grinding jars

⚠ CAUTION If the additional equipment is incorrectly loaded, the grinding jars may crack during the grinding process. Observe the specifications regarding the sizes of the grinding balls.

9.1 Adapter for conical centrifuge tubes and adapter for 30 ml wide mouth bottles

For the grinding process, the device can be equipped with an adapter for centrifuge tubes or an adapter for 30 ml wide mouth bottles. Both adapters allow simultaneous grinding of up to 8 samples in the respective grinding vessels.

Mount the adapter as follows:

⚠ CAUTION Always mount the adapter in a symmetrical arrangement. Otherwise, centrifuge tubes or wide mouth bottles may be ejected from the adapter during the grinding process.

⇒ Insert the centrifuge tubes or wide mouth bottles into the adapter. In order to do this, at first insert the bottom of the tube or wide mouth bottle into the rubberised recess on the side plate of the adapter. Push the opposite side of the lid into the adapter with light pressure so that the tube or wide mouth bottle sits at a 90° angle to the side plates.

⇒ Open the grinding jar holder as described in the previous chapters.

⇒ Insert the adapter into the opened grinding jar support.

NOTICE Please ensure the correct orientation of the adapters when inserting them into the grinding jar supports. According to their arrangement, the adapters are marked with "R" for the right grinding jar support and "L" for the left grinding jar support of the device.

⇒ Close the grinding jar support as described in the previous chapters. This fastens the centrifuge tubes or the wide mouth bottles in the adapter. It must be ensured that all centrifuge tubes or wide mouth bottles are arranged in parallel.

⇒ Start the grinding process with the required parameters.



Abb. 40: Centrifuge tube adapter in grinding jar support



Abb. 41: Permissible arrangement of centrifuge tubes or wide mouth bottles

⚠ CAUTION Centrifuge tubes and wide mouth bottles are not suitable for grinding hard-brittle materials. They are disposable plastic vessels which must not be used more than once.

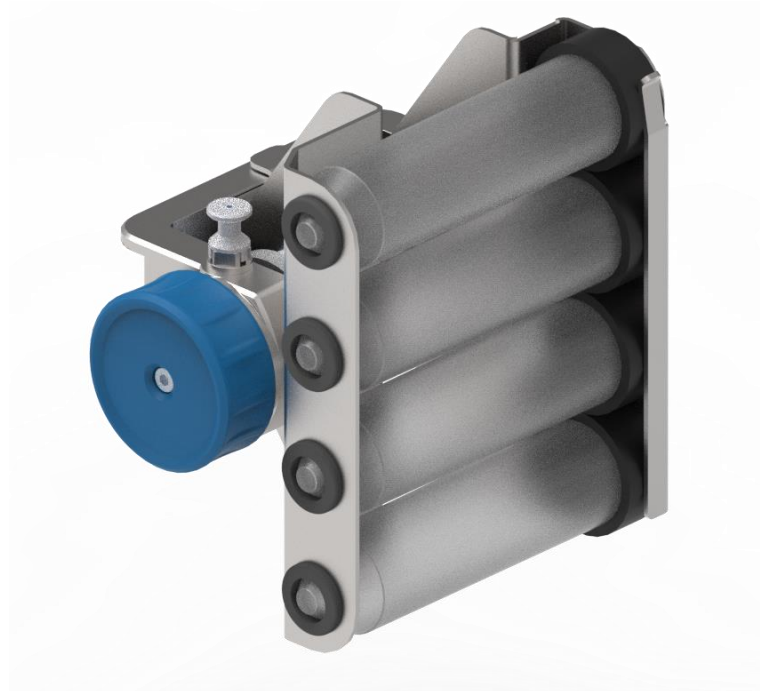
The filling of the vessels deviates from the 1/3 rule, particularly regarding the application and filling:

Example 1	
Grinding balls	Glass beads, approx. 50 % of the filling quantity of the vessel
Sample material	Cell suspension Fill the vessel filled with glass beads up to the lower edge of the rim

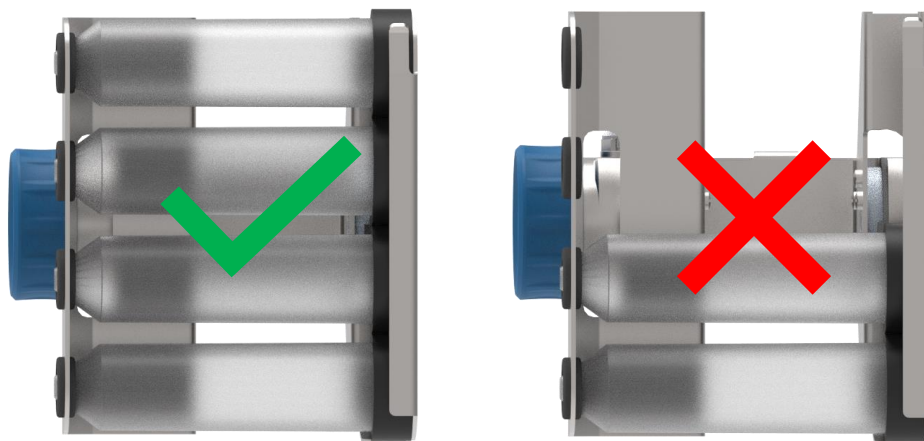
Example 2	
Grinding balls	2 x 15 mm steel grinding balls
Sample material	Dried plant parts, approx. 50 % of the filling quantity of the vessel

9.2 Adapter for 4 x 5 ml steel grinding jars

The device can be equipped with an adapter for 4 x 5 ml steel grinding jars for the grinding process. The adapter enables simultaneous grinding of up to 8 samples.

Mount the adapter as follows:

NOTICE Always load the adapter in a symmetrical arrangement. Failure to do so may result in damage to the device and uneven grinding process due to their proper loading.

- ⇒ Insert the reaction vials into the adapter with the bottom first.
- ⇒ Screw the lid onto the adapter.
- ⇒ Open the grinding jar holder as described in the previous chapters.
- ⇒ Insert the adapter into the opened grinding jar support.
- ⇒ Close the grinding jar support as described in the previous chapters.
- ⇒ Start the grinding process with the required parameters.



Abb. 42: Adapter for 4 x 5 ml steel grinding jars in the grinding jar support



Abb. 43: Permissible arrangement of the steel grinding jars in the adapter

10 Servicing

CAUTION

C13.0013

Risk of injury

Improper repairs

- Unauthorised and improper repairs can cause injuries.
- **Repairs to the device may only be carried out by Retsch GmbH, an authorised representative or by qualified service technicians.**
- **Do not carry out any unauthorised or improper repairs to the device!**

This chapter contains descriptions on cleaning and servicing the device.



This Manual does not contain repair instructions. All repairs must be conducted by Retsch GmbH, an authorised representative or by Retsch service technicians.

 CAUTION The device must always be switched off and disconnected from the mains before any interventions for cleaning and maintenance purposes can be performed.

10.1 Cleaning

To guarantee the reliability and operational safety of the device, it must be cleaned as necessary and at least once a month.



Use a damp cloth and gentle cleaning agent to remove stubborn deposits.

WARNING

W11.0003

Risk to life caused by an electric shock

Cleaning live parts with water

- Cleaning the device with water can lead to life-threatening injuries caused by an electric shock if the device has not been disconnected from the power supply.
- **Only carry out cleaning work on the device when it has been disconnected from the power supply.**
- **Use a cloth moistened with water for cleaning.**
- **Do not clean the device under running water!**



CAUTION

C14.0031

Risk of injury

Cleaning with compressed air

- When using compressed air for cleaning purposes dust and remnant of the sample material can be flung around and injure eyes.
- **Always wear safety glasses when cleaning with compressed air.**
- **Observe the material safety data sheets of the sample material.**



10.1.1 Cleaning the outside of the device

⇒ Clean the housing of the device with a damp cloth and, if necessary, a household cleaning agent. Make sure that no water or cleaning agent gets into the interior of the device.

⇒ Only use neutral cleaning agents. Do not use solvent-based cleaners! Acetone is not permitted!

Test cleaning products on an inconspicuous spot.

10.1.2 Cleaning the collecting tray

Clean the collecting tray using a damp cloth and a standard household cleaning agent if necessary.

10.1.3 Cleaning the inside

Clean the inside of the device using a vacuum cleaner or a damp cloth and a standard household cleaning agent if necessary.

During cleaning, the collecting receptacle underneath the grinding stations can be removed and cleaned separately.

Ensure that no water or detergent gets inside the device.

10.1.4 Cleaning the grinding jar

All grinding jars, including those with glued-in ceramic inserts, can be cleaned with alcohol, petroleum ether or normal household washing-up liquid.

① Cleaning in a household dishwasher is also possible.

After cleaning, the grinding jars can be dried in the drying cabinet at the following temperatures:

Grinding jar material	Temperature
Hardened steel	Up to 200 °C
Stainless steel	Up to 200 °C
Tungsten carbide(TC)	Up to 150 °C
Zirconium oxide	Up to 120 °C

10.1.5 Cleaning the grinding balls

All grinding balls can be cleaned with alcohol, petroleum ether or normal household washing-up liquid.

① Cleaning in a household dishwasher is also possible.

10.2 Maintenance

The MM 400 is maintenance-free.

No maintenance work needs to be carried out if the device is used as intended.

⚠ CAUTION

C15.0015

Risk of injury

Improper modifications to the device

- Improper modifications to the device can result in injuries.
- **Do not make any unauthorised changes to the device.**
- **Only use the spare parts and accessories approved by Retsch GmbH!**

10.3 Wear

⚠ CAUTION

C16.0013

Risk of injury

Improper repairs

- Unauthorised and improper repairs can cause injuries.
- **Repairs to the device may only be carried out by Retsch GmbH , an authorised representative or by qualified service technicians.**
- **Do not carry out any unauthorised or improper repairs to the device!**

The grinding tools may become worn, depending on the frequency of the grinding operation and the sample material. The grinding jars and, depending on the presence, the grinding balls or grinding set should be regularly checked for wear and replaced if necessary.

Likewise, all existing sealing gaskets (of grinding tools and in the device) should be checked for wear regularly and replaced if necessary.

10.3.1 Replacing the Fuses

⚠ WARNING

W12.0014

Risk to life caused by an electric shock

Exposed contacts

- Replacing the fuses without pulling out the mains plug can lead to life threatening injuries caused by an electric shock on contact with the fuse holder or the live contacts on the fuse.
- **Pull out the mains plug before replacing the fuses.**

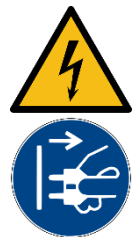

Tension	Fuse
100 – 240V	2x 4A slow, 250VAC

There are two fuses located in the fuse drawer on the back of the device. Fuses may be replaced by trained specialist personnel.

- ⇒ Remove the fuse drawer.
- ⇒ Replace the defective fuse in the fuse drawer.
- ⇒ Push the fuse drawer back in until you hear it click into place.

10.4 Returning for repair and maintenance



Fig. 44: Return form

The acceptance of devices and accessories of the Retsch GmbH for repair, maintenance or calibration can only be effected, if the return form including the decontamination declaration service has been correctly and fully completed.

- ⇒ Download the return form located in the download section "Miscellaneous" on the Retsch GmbH homepage (<http://www.retsch.com/downloads/miscellaneous/>).
- ⇒ When returning a device, attach the return form to the outside of the packaging.

In order to eliminate any health risk to the service technicians, Retsch GmbH reserves the right to refuse the acceptance and to return the respective delivery at the expense of the sender.

11 Accessories

Information about available accessories and the corresponding manuals can be found directly on the Retsch GmbH (<https://www.retsch.com>) website under the "Downloads" section for the device.

Information about parts subject to wear and tear and small accessories can be found in the complete catalogue for the Retsch GmbH, likewise available on the website.

In the event of questions about spare parts, please contact the representative for Retsch GmbH in your country or contact Retsch GmbH directly.

12 Disposal

In the case of a disposal, the respective statutory requirements must be observed. In the following, information on the disposal of electrical and electronic devices in the European Community are given.

Within the European Community the disposal of electrically operated devices is regulated by national provisions that are based on the EU Directive 2012/19/EU on Waste Electrical and Electronic Equipment (WEEE).

Accordingly, all devices supplied after August 13th 2005 in the business-to-business area, to which this product is classified, may no longer be disposed of with municipal or household waste. To document this, the devices are provided with the disposal label.

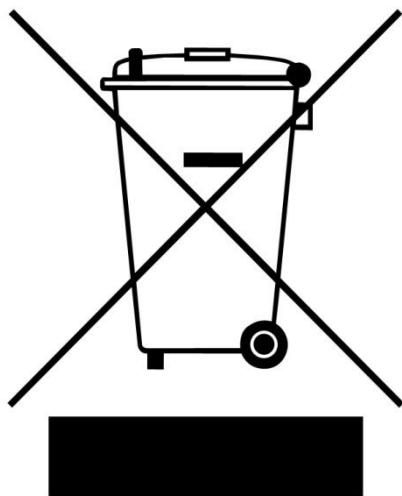

Fig. 45: Disposal label

Since the disposal regulations worldwide and also within the EU may differ from country to country, the supplier of the device should be consulted directly in case of need.

This labelling obligation is applied in Germany since March 23rd 2006. From this date on, the manufacturer must provide an adequate possibility of returning all devices delivered since August 13th 2005. For all devices delivered before August 13th 2005 the end user is responsible for the proper disposal.

13 Index

- 5**
- 5 ml steel grinding jars 71
- A**
- Accessories 76
- Accessories included with delivery 25
- Adapter 69
- Ambient temperature 27
- Amendment status 7
- Amount of energy 33
- Amperage 24
- Applications 17
- Areas of application 17
- B**
- Back 22
- Bar code 24
- Beeper 63
- Brightness 63
- C**
- Calibration 65, 66, 75
- Capacity 24
- Causes 14, 15
- CE marking 24
- Centrifuge tubes 69
- Cleaning 72
- Cleaning the collecting tray 73
- Cleaning the grinding balls 73
- Cleaning the grinding jar 73
- Cleaning the inside 73
- Cleaning the outside of the device 73
- Closing the grinding jar 38
- Complaints 25, 26
- Condensation 26
- Confirmation form for the managing operator 16
- Connecting the device to the power supply 30
- Connection information 65
- Control 47
- Controlling the grinding process 53
- Copyright 7
- Cryogenic burns 14
- Cryogenic grinding 44
- Cycle programme mode 58
- Cycle programme number 60
- D**
- Dangers 13, 14
- Date 65
- Date and time 63, 65
- Degree of protection 18
- Delete 57
- Deleting the cycle programme 62
- Device
 - close 32
 - open 32
- Device control 46, 64
- Device designation 24
- Device hood 21
- Diagram of the menu navigation 51
- dial 46
- Dial 46, 65
- Dial 63
- Disclaimer 7
- Disconnection from the mains 26
- Display
 - Software 64
- Disposal 77
 - label 77
 - regulations 77
- Disposal label 24
- E**
- Editing the cycle programme 61
- Editor for the cycle programme 61
- Editor mode 55, 57, 60, 61
- Electrical connection 29
- Electromagnetic compatibility 18
- EMC 18
- Emissions 19
- Error
 - E10 67
 - E13 67
 - E20 67
 - E23 67
 - E25 68
 - E41 68
 - E50 68
 - E51 68
 - E52 68
 - E53 68
 - E88 68
- Error messages 67
- Ethernet interface 22
- Explanations of the safety instructions 8
- External fuse 29
- F**
- Facilitating the power connection 30
- Feed material 17
- Feed size 34, 35
- Filling the grinding jar 38
- Firmware 64
- First commissioning 29
- Fixed pressure plate 21
- Fourfold adapter 71
- Frequency 29
- Front 20
- Function elements 46, 48
- Fuse strength 24
- Fuse type 24
- Fuses
 - replacing 74

G	
Gallery view	55, 57
General conduct in the case of an accident	14
General rules of conduct for splashes with liquid nitrogen	15
Grinding aid	45
Grinding ball	38
size	34
Grinding balls	37
Grinding jar	38
fill level	34
identification	34
inserting	39, 40
material	34, 73
size	34
Grinding jar filling	38
Grinding jar holder	21, 40
Grinding jar size	33, 34, 35
Grinding jar support	21
grinding jars	37
grinding jars	37
grinding jars (materials)	18
Grinding noise	19
Grinding process	41
Grinding stations	21
Grinding time	55
H	
Hardened steel	73
Hearing loss	19, 31
Hood	33
Hood of the device	43
Humidity	27
I	
Improper use	9
Info	63
Information notes	67
Inserting the grinding jar	40
Installation	25
Installation height	27
Installation site conditions	26
Installing additional equipment	69
Intended use	9
Intended use of the device	9
L	
L_{eq}	19, 20
Locking pin	22
M	
Main menu	52, 60
Main switch	32
Mains frequency	24
Mains supply	29
Maintenance	16, 73, 75
Manual	7, 9, 16
Manufacturer's address	24
Maximum achievable final fineness level	18
Maximum feed amount	18
Maximum feed size	18
Maximum relative humidity	27
Menu interface of the touchscreen	47
Menu navigation	51
Movable pressure plate	21
MyRetsch	63
N	
Navigation area	47
Noise levels	19
Notes on the manual	7
Number of grinding stations	18
O	
Obligations of the operating company	10
Opening aid	35
Opening aids	35, 36
Opening the grinding jar	37
Opening the grinding jar support	39
Operating hours	64
Operating instructions	16
Operating the device	31
Operation	28
Oxygen deficiency	13
P	
Packaging	25
Parameter displays	47
Parameter sets	61
Parameter settings	47, 61, 62
Part number	24
Parts subject to wear and tear	76
Pause cycle programme	60
Pause grinding process	53, 55
Pausing the grinding process	53
Personal protective equipment	11
Personal protective equipment (PPE)	11
Personnel	10
Power version	24
Power warning	23
PPE	11
Preparing the grinding jar	36
Preventing damage to equipment	13
Preventing risks during normal operation	12
Program editing	57
selecting	55
Program mode	54
Program preset	58
Programmable cycles	18
Programme deleting	58
saving	58
Programme control	64
Programme editor	57
Programme mode	54, 56
Programme number	55
Programme view	56
Protective equipment	11
Provisions	10

Q		Switching the device on/off	32
Qualification of personnel	11	Switch-on time	17
R		Symbols	7
Read the operating instructions	23	System setting	53
Recommendations	14, 15	system settings	65
Recommended ball sizes	34	System settings	62, 63
Recommended grinding jar filling	34	T	
Recommended number of grinding balls	34, 35	Target group	9
Remaining grinding time	53	TC	73
Remaining grinding timer	55	Technical data	17
Remove packaging	27	Temperature	73
Remove the grinding jar	43	Temperature fluctuations	26
Removing the sample material	42	Temperature range	27
Repair	12, 72, 74, 75	Temporary storage	26
Repair instructions	12	Time	65
Repetitions cycle	60, 61	Total cycle programme duration	62
Required floor space	19	Total cycle programme time	60, 61
Return	25	Touchscreen	46
Return device	77	Touchscreen and dial	46
Return form	75	Transport	25, 28
Returning for repair and maintenance	75	Transport damage	26
S		Transport safety device	
Safety	9	releasing	28
Safety instructions on the handling of liquid		Transportation lock	28
nitrogen	13, 14	removing	28
Sample volume	34, 35	Tungsten carbide	73
Save	57, 62	Type label	23
Saving the cycle programme	62	Type plate	24, 29
Scroll bar	47	description	24
Scrollbar	57	U	
Selecting a cycle	60	UKCA marking	24
Selecting the cycle programme	60	USB interface	22
Serial number	24, 64	V	
Service address	12	Vibration frequency	53, 55, 57
Service area	63	Vibration frequency setting	18
Service environment	65	Vibrations	26, 39
Service information	65	Views of the device	20
Servicing	72	Voltage	29
Signalling device	64	Volume decrease during grinding	34
Signs	7	Volume increase during grinding	34
Signs on the device	23	W	
Site conditions	19	Warning	
Small accessories	76	Information	8
Software update	65	Warranty claim	25
Sound level	19, 31	Wear	74
Spare parts	76	Wear hearing protectors	23
Special grinding methods	44	Weight	18, 24
Specifications regarding grinding balls and		Wet grinding	45
grinding jars	33	with highly flammable materials	45
Stainless steel	73	Wide mouth bottles	69
Start cycle programme	60, 61	Y	
Start grinding process	53, 55, 57	Year of production	24
Starting the grinding process	42	Z	
Starting the grinding process	53	Zirconium oxide	73
Stop cycle programme	60		
Stop grinding process	53		
Stop grinding process	55		
Stopping the grinding process	54		

MIXER MILL

MM 400 | 20.715.xxxx

EU DECLARATION OF CONFORMITY

We, represented by the undersigned, hereby declare that the above device complies with the following directives and harmonised standards:

Machinery Directive 2006/42/EC

Applied standards, in particular:

DIN EN ISO 12100	Machine Safety - General Design Principles
DIN EN 61010-1	Safety Regulations for Electrical Measurement, Control, Regulation and Laboratory Devices

Electromagnetic compatibility 2014/30/EU (tested at 230 V, 50 Hz)

Applied standards, in particular:

EN 55011	Industrial, scientific and medical equipment - Radio-frequency disturbance characteristics - Limits and methods of measurement
DIN EN 61326-1	Electrical equipment for measurement, control and laboratory use - EMC requirements

Restriction of hazardous substances (RoHS) 2011/65/EU

Applied standards, in particular:

DIN EN IEC 63000	Technical documentation for the assessment of electrical and electronic products with respect to the restriction of hazardous substances
------------------	--

Authorised person for compilation of the technical documentation:

Julia Kürten (Technical Documentation)

Furthermore, we declare that the relevant technical documentation for the above device has been prepared in accordance with Annex VII Part A of the Machinery Directive and we undertake to submit the documentation to the market surveillance authorities on request.

In the event of a modification of the device not agreed on by Retsch GmbH, as well as the use of non-approved spare parts or accessories, this declaration loses its validity.

Retsch GmbH

Haan, 09/2023



Dr. Kevin Schmitz, Head of Development





Retsch[®]

Copyright

© Copyright by
Retsch GmbH
Retsch-Allee 1-5
42781 Haan
Germany