Manual

Rotating Sample Divider PT 300



Translation



Copyright

© Copyright by
Retsch GmbH
Retsch-Allee 1-5
42781 Haan
Germany

Table of Contents

1	Notes on the manual	6
1.1	Disclaimer	6
1.2	Copyright	6
2	Safety	7
2.1	Explanations of the Safety Instructions	7
2.2	General Safety Instructions	8
2.3	Repairs	9
2.4	Responsibility of the operating company	9
2.5	Personnel qualification and target group of this manual	10
2.6	Confirmation Form for the Managing Operator	11
3	Packaging, Transport and Installation	12
3.1	Packaging	12
3.2	Transport	12
3.3	Temperature Fluctuations and Condensation	12
3.4	Conditions for the Installation Site	13
3.5	Electrical Connection	14
3.6	Transport	15
3.7	Installing the device	16
3.8	Type Plate Description	17
4	Technical data	18
4.1	Intended use of the device	18
4.2	Divider modules	19
4.3	Funnel	19
4.4	Feed size	19
4.5	Mains connection	19
4.6	Rated Power	19
4.7	Motor Rotation Speed	20
4.8	Emissions	20
4.8.1	Noise levels	20
4.9	Degree of Protection	20
4.10	Protective Equipment	20
4.11	Dimensions and Weight	20
4.12	Required Floor Space	20
4.13	Installation drawing	21
5	Views of the device	23
5.1	Front view	23
5.2	Interior view	24
5.3	Operating elements and displays	25
6	Operating the device	26
6.1	Opening the device	26
6.2	Closing the device	27
6.3	Preparing the division process	27
6.3.1	Inserting the riser for divider modules	27
6.3.2	Inserting the divider module	28
6.3.3	Inserting the vibratory feeder	29
6.3.4	Adjusting the gap size	31
6.3.5	Connecting the dust extraction	32
6.4	Control panel – Operating the machine	32
6.4.1	Start menu	32
6.4.2	Settings	33
6.4.3	Starting the division process	36
6.5	Finishing the division process	37

7	Error messages	39
8	Cleaning, Wear and Maintenance	40
8.1	Cleaning	40
8.1.1	Cleaning the machine housing.....	40
8.1.2	Cleaning the feed hopper and the interior	40
8.2	Wear	41
8.3	Maintenance	41
9	Return for Service and Maintenance	42
10	Disposal.....	43
11	Index	44

1 Notes on the manual

This manual provides technical guidelines for the safe operation of the device. Read this manual through carefully before installing, putting into service and operating the device. Reading and understanding this manual is essential for handling the device safely and as intended.

This manual does not contain any repair instructions. Please contact your supplier or contact Retsch GmbH directly if anything is unclear or you have questions about these guidelines or the device, or in the case of any faults or necessary repairs.

You can find further information about your device at <https://www.retsch.com> on the pages for the specific device concerned.

Amendment status:

The document amendment 0003 of the "Rotating Sample Divider PT 300" manual has been prepared in accordance with the Directive of Machinery 2006/42/EC.

1.1 Disclaimer

This manual has been prepared with great care. We reserve the right to make technical changes. We assume no liability for personal injuries resulting from the failure to follow the safety information and warnings in this manual. No liability will be assumed for damage to property resulting from the failure to follow the information in this manual.

1.2 Copyright

This document or parts of it or its content may not be reproduced, distributed, edited or copied in any form without prior written permission of Retsch GmbH. Damage claims shall be asserted in the case of infringements.

2 Safety

Safety Officer

The operating company itself must ensure the following with respect to persons authorised to work on the device:

- that they have read and understood all regulations contained in the chapter on safety;
- that they are aware before they start work of all instructions and regulations for the target group related to the work;
- that they have easy access to the manual for this device at all times;
- that they have been familiarised with the safe and correct handling of the device before starting work on it, by means of a verbal introduction by a competent person and/or using this manual.

⚠ Improper operation can lead to personal injuries. The operating company itself is responsible for its safety and that of its staff. The operating company itself must ensure that no unauthorised persons have access to the device.

Target group

All those operating, cleaning or working with or on the device.

This device is a modern, powerful product from Retsch GmbH and has been developed in line with the state-of-the art. The device is safe to use when operated correctly and when following the instructions in this manual.

⚠ People under the influence of intoxicating substances (medications, drugs, alcohol) or who are overtired may not operate the device or work on the device.

2.1 Explanations of the Safety Instructions

The following **warnings** in this manual warn of possible risks and damage:

⚠ DANGER	<i>D1.0000</i>
<p>Risk of fatal injuries Source of danger</p> <ul style="list-style-type: none"> – Possible consequences if the danger is ignored. • Instructions and information on how to avoid the risk. 	

Fatal or serious injuries may result if the “Danger” sign is disregarded. There is a **very high risk** of a life-threatening accident or lasting personal injury. The signal word **⚠ DANGER** is additionally used in the running text or in instructions.

⚠ WARNING	<i>W1.0000</i>
<p>Risk of life-threatening or serious injuries Source of danger</p> <ul style="list-style-type: none"> – Possible consequences if the danger is ignored. • Instructions and information on how to avoid the risk. 	

Life-threatening or serious injuries may result if the “Warning” sign is disregarded. There is an **increased risk** of a serious accident or of a possibly fatal personal injury. The signal word **⚠ WARNING** is additionally used in the running text or in instructions.

⚠ CAUTION

C1.0000

Risk of injuries

Source of danger

- Possible consequences if the danger is ignored.
- **Instructions and information on how to avoid the risk.**

Average to slight injuries may result if the “Caution” sign is disregarded. There is an average or slight risk of an accident or personal injury. The signal word **⚠ CAUTION** is additionally used in the running text or in instructions.

NOTICE

N1.0000

Type of damage to property

Source of the damage to property

- Possible consequences if the information is ignored.
- **Instructions and information on how to avoid the damage to property.**

Damage to property may result if the information is disregarded. The signal word **NOTICE** is additionally used in the running text or in instructions.

2.2 General Safety Instructions

⚠ CAUTION

C2.0002

Risk of injury

Lack of knowledge of the manual

- The manual contains all safety-related information. Disregarding the manual can therefore lead to injuries.
- **Read the manual carefully before operating the device.**



⚠ CAUTION

C3.0015

Risk of injury

Improper modifications to the device

- Improper modifications to the device can result in injuries.
- **Do not make any unauthorised changes to the device.**
- **Only use the spare parts and accessories approved by Retsch GmbH!**

NOTICE

N2.0012

Changes to the device

Improper modifications

- The conformity declared by Retsch GmbH with the European Directives will lose its validity.
- Any warranty claims will be terminated.
- **Do not make any modification to the device.**
- **Use spare parts and accessories that have been approved by Retsch GmbH exclusively.**



2.3 Repairs

This manual does not contain any repair instructions. For safety reasons, repairs may only be carried out by Retsch GmbH or an authorised representative or by qualified service technicians.

In case of repair, please inform...

- ...the Retsch GmbH representative in your country,
- ...your supplier, or
- ...Retsch GmbH directly.

Service address:

2.4 Responsibility of the operating company

The user of the machine (the operating company) is responsible for ensuring that every person who works on the machine has been given precise instructions on the basis of this Manual (commissioning, operation, servicing). Training for operators must cover the following points:

- Intended purpose of the machine
- Hazardous areas
- Safety provisions
- You must be satisfied that staff have the requisite qualifications
- General instructions and actions in an emergency
- Applicable accident prevention regulations
- Personal protective clothing required
- Operation of the machine in line with this Manual
- Accepted, applicable rules governing occupational health and safety

Incorporate the PT 300_600 into your emergency planning:

- Integrate the PT 300_600 into your operating procedures regulating conduct in emergency situations.
- To prevent accidents during work processes, incorporate the PT 300_600 into your risk assessment in acc. with the German Ordinance on Industrial Health and Safety (BetrSichV).
- Take into consideration fire-fighting measures, combatting the effect of leaking substances, potential radiation, rescuing people, first-aid measures.

2.5 Personnel qualification and target group of this manual

This manual is intended for trained assembly personnel , maintenance staff and users . Training must be provided in the language of the personnel concerned so that all instructions are understood. As such the following personnel qualifications are necessary:

Assembly, commissioning, instruction, troubleshooting, servicing work, as described in this manual	Skilled technical staff as well as external service providers who speak German and the language of the operating personnel. The usual skills communicated during training, e.g. as a plant fitter, mechatronics engineer or toolmaker, are prerequisites for the assembly, commissioning and troubleshooting of the machine. Employees must be able to manage all applicable mechanical tasks and be familiar with and have experience of dealing with these.
Operation	Education/training in accordance with the above section, responsibilities of trained employees.
Servicing/repairs	They must be experienced, trained professionals, familiar with requirements and guidelines.

2.6 Confirmation Form for the Managing Operator

This manual contains essential instructions for operating and maintaining the device which must be strictly observed. It is essential that they be read by the user and by the qualified staff responsible for the device before the device is commissioned. This manual must be available and accessible at the place of use at all times.

The user of the device herewith confirms to the managing operator (owner) that he has received sufficient instructions about the operation and maintenance of the system. The user has received the manual, has read and taken note of its contents and consequently has all the information required for safe operation and is sufficiently familiar with the device.

The managing operator should for legal protection have the user confirm the instruction about the operation of the device.

I have read and taken note of the contents of all chapters in this manual as well as all safety instructions and warnings.	
User	
Surname, first name (block letters)	
Position in the company	
Place, date and signature	
Managing operator or service technician	
Surname, first name (block letters)	
Position in the company	
Place, date and signature	

3 Packaging, Transport and Installation

3.1 Packaging

The packaging has been adapted to the mode of transport. It complies with the generally applicable packaging guidelines.

NOTICE

N3.0001

Complaint or return

Keeping the packaging

- Inadequate packaging and insufficient securing of the device can jeopardise the warranty claim in the event of a complaint or return.
- **Keep the packaging for the duration of the warranty period.**

3.2 Transport

NOTICE

N4.0017

Damage to components

Transport

- Mechanical or electronic components may be damaged during transport. The device must not be knocked, shaken or thrown during transport.
- **Move the device gently during transport.**

NOTICE

N5.0014

Complaints

Incomplete delivery or transport damage

- The forwarding agent and Retsch GmbH must be notified immediately in the event of transport damage. It is otherwise possible that subsequent complaints will not be recognised.
- **Please check the delivery on receipt of the device for its completeness and intactness.**
- **Notify your forwarding agent and Retsch GmbH within 24 hours.**

3.3 Temperature Fluctuations and Condensation

NOTICE

N6.0016

Damaged components due to condensation

Temperature fluctuations

- The device may be exposed to substantial fluctuations in temperature during transport. The ensuing condensation can damage electronic components.
- **Wait until the device has acclimatised before putting it into service.**

Temporary storage:

In case of an interim storage the device must be stored dry and within the specified ambient temperature range.

3.4 Conditions for the Installation Site

NOTICE

N7.0021

Ambient temperature

Temperatures outside the permitted range

- Electronic and mechanical components may be damaged.
- The performance data alters to an unknown extent.
- **Do not exceed or fall below the permitted temperature range (5 °C to 40 °C ambient temperature) of the device.**
- Installation height: max. 2 000 m above sea level
- Ambient temperature: 5 °C – 40 °C
- Maximum relative humidity < 80 % (at ambient temperatures ≤ 31 °C)

For ambient temperatures U_T between 31 °C and 40 °C, the maximum relative humidity value L_F linearly decreases according to $L_F = -(U_T - 55) / 0.3$:

Ambient temperature	Max. rel. humidity
≤ 31 °C	80 %
33 °C	73.3 %
35 °C	66.7 %
37 °C	60 %
39 °C	53.3 %
40 °C	50 %

NOTICE

N8.0015

Humidity

High relative humidity

- Electronic and mechanical components may be damaged.
- The performance data alters to an unknown extent.
- **The relative humidity in the vicinity of the device should be kept as low as possible.**

3.5 Electrical Connection

⚠ WARNING W2.0015

Risk to life caused by an electric shock
 Connection to socket without a protective earth conductor

- Connecting the device to sockets without a protective earth conductor can lead to life-threatening injuries caused by an electric shock.
- **Always operate the device using sockets with a protective earth conductor (PE).**



NOTICE N9.0022

Electrical connection
 Failure to observe the values on the type plate

- Electronic and mechanical components may be damaged.
- **Connect the device only to a mains supply matching the values on the type plate.**

⚠ WARNING When connecting the power cable to the mains supply, use an external fuse that complies with the regulations applicable to the place of installation.

- Check the type plate for details on the necessary voltage, frequency, and maximum external current source fuse for the device.
- The listed values must agree with the existing mains supply.
- Only use the supplied power cable to connect the device to the mains supply.

⚠ WARNING W3.0005

Danger to life due to electric shock or fire
 Incorrect connection to the power supply may result in parts of the housing or cables being live and in fires starting.

- Serious injuries or death due to an electric shock.
- Serious injuries or death due to fires.
- **The device may only be connected by a qualified electrician.**



The drive on the machine is fitted with a frequency converter . In order to comply with the EMC Directive , this is equipped with a mains filter and shielded cables to the motor. If your mains connection for the machine includes a residual current device , the anti-interference circuit on the frequency converter may result in false alarms on the residual current device when it is switched on – it is always switched on when the grinding chamber cover is closed – without there being any fault on the machine or the mains installation.

In accordance with the state of the art, selected all current sensitive residual current devices are recommended for such cases. The trip current must be adequately dimensioned because short-term capacitive compensation currents (shielded cable, mains filters) can easily lead to false alarms when switched on.

In some circumstances it may be necessary to operate the machine without the residual current device, although in this case checks must be conducted to ensure that this does not contradict any local regulations of electricity companies or other institutions as well as any applicable standards.

⚠ WARNING High leakage currents of > 3.5 mA alternating current can occur on the frequency converter required and used in this machine. A fixed ground connection must therefore be provided for stationary operation of the machine.

The following must be taken into consideration during preparation for commissioning and maintenance:

- Fixed wiring in accordance with applicable standards (1~/N/PE) must be provided in close proximity to the machine.
- The fixed wiring must have a minimum copper cross section of 3 x 2.5 mm² (L, N and PE).
- A connection must be provided for the additional protective earthing with at least 10 mm² copper.

3.6 Transport

⚠ WARNING		<small>W4.0005</small>
<p>Risk of injury due to the device falling down Lifting the device above head height</p> <ul style="list-style-type: none"> – The device can fall causing serious injuries when lifted above head height. • Never lift the device above head height! 		
		

NOTICE		<small>N10.0018</small>
<p>Transportation lock Transport without transportation lock, or operation with transportation lock</p> <ul style="list-style-type: none"> – Mechanical components may be damaged. • Only transport the device with mounted transportation lock. • Do not operate the device with built-in transportation lock. 		

NOTICE		<small>N11.0017</small>
<p>Damage to components Transport</p> <ul style="list-style-type: none"> – Mechanical or electronic components may be damaged during transport. The device must not be knocked, shaken or thrown during transport. • Move the device gently during transport. 		

The device is secured for transport by a transport lock on the transport pallet. The device has to be transported with a forklift truck as follows:

- Approach the packed device with the forklift and position the forks centrally underneath the device.
- Carefully lift the device and move it to its installation site.

3.7 Installing the device

The installation site of the device must be a level and solid surface.

Set up the device as described below:

- Remove the wooden box.
- Remove the transport lock which secures the device on the transport pallet with a 17 mm wrench.
- Carefully approach the device from the right-hand side and place the forks centrally underneath the device.
- Carefully lift the device and move it to its installation site.

NOTICE The device must be secured before it is put into operation, because otherwise it may cause damage to the device.

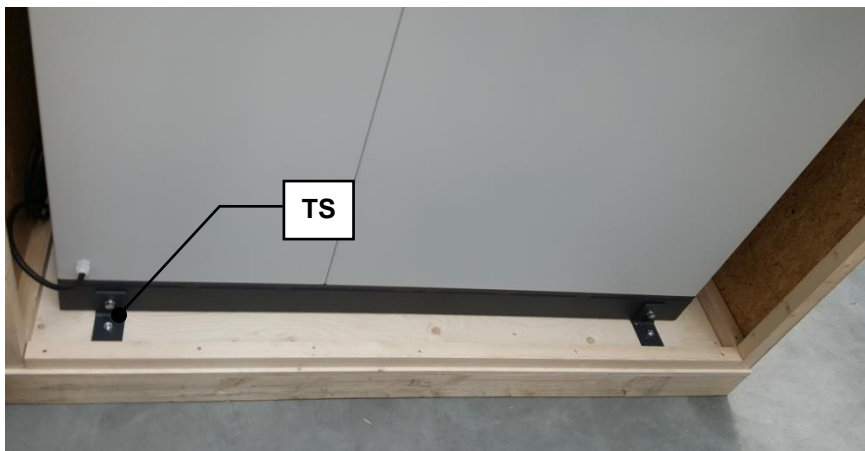

Fig. 1: Loosening the transport lock from the transport pallet

3.8 Type Plate Description

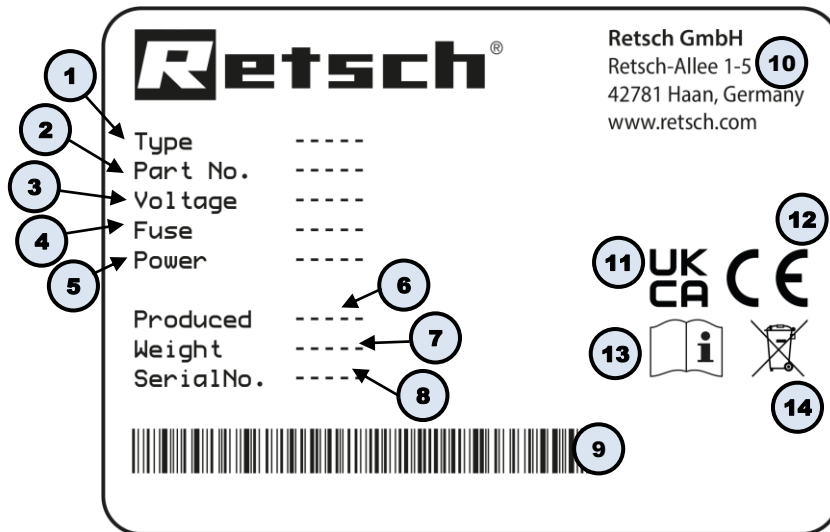

Fig. 2: Type plate

- 1 Device designation
- 2 Part number
- 3 Power version, Mains frequency
- 4 Fuse type and fuse strength
- 5 Capacity, Amperage
- 6 Year of production
- 7 Weight
- 8 Serial number
- 9 Bar code
- 10 Manufacturer's address
- 11 UKCA marking
- 12 CE marking
- 13 Safety warning: Read the manual
- 14 Disposal label

① In the case of queries please provide the device designation (1) or part number (2), as well as the serial number (8) of the device.

4 Technical data

4.1 Intended use of the device

⚠ CAUTION

C4.0005

Risk of injury

Potentially explosive atmosphere

- The device is not suitable for use in potentially explosive atmospheres. Operating the device in a potentially explosive atmosphere can lead to injuries caused by an explosion or fire.
- **Never operate the device in a potentially explosive atmosphere!**

⚠ CAUTION

C5.0006

Risk of injury

Sample material that is harmful to health

- Sample material that is harmful to health can injure people (illness, contamination).
- **Use suitable extraction systems with sample material that is harmful to health.**
- **Use suitable personal protective equipment with sample material that is harmful to health.**
- **Take note of the safety data sheets for the sample material.**



⚠ CAUTION

Risk of hearing loss

High sound level

- A high sound level may arise depending on the type of material and the duration of sample division. Excessive noise in terms of intensity and duration can cause impairments or lasting damage to hearing.
- **Ensure you take suitable noise protection measures.**
- **Wear hearing protectors when there is loud or persistent noise.**



Target group: User (operating company), operators

Machine type designation: PT 300_600

The PT 300_600 sample divider is used for fast, loss-free and reproducible sample division on free-flowing materials.

The dividing process takes place under dry conditions. By using the appropriate module, the PT 300_600 may be deployed both in continuous and batch processing mode.

Any other use is regarded as improper use and may result in damage to equipment or even to personal injuries.

Advantages

- Fast division of large quantities
- Adjustable vibration intensity of the feeder
- Adjustable speed
- Reproducible results
- Continuous and batch processing module available
- Parameters can be easily adjusted using the display

NOTICE

N12.0007

Range of application of the device

Long-term operation

- This laboratory device is designed for eight-hour single-shift operation with a duty cycle of 30 %.
- **This device may not be used as a production machine nor is it intended for continuous operation.**

4.2 Divider modules

Divider modules for the allocation of up to 30 litres

- Module for 4 divided samples (7,5 litres per segment)
- Module for 6 divided samples (5 litres per segment)
- Module for 8 divided samples (3,75 litres per segment)
- Module for 10 divided samples (3 litres per segment)
- Module for 1 divided sample with rejection mechanism

Please note that the modules for 4, 6, 8 and 10 divided samples (batchwise allocation of up to 30 litres) must always be used in combination with the supplied riser.

Divider modules for the allocation of up to 60 litres

- Module for 4 divided samples (15 litres per segment)
- Module for 6 divided samples (10 litres per segment)
- Module for 8 divided samples (7.5 litres per segment)
- Module for 10 divided samples (6 litres per segment)
- Module for 1 divided sample with rejection mechanism

4.3 Funnel

- Funnel, stainless steel, 30 litre capacity
- Funnel, stainless steel, 60 litre capacity

4.4 Feed size

- Vibratory feeder up to 30 mm.
- Vibratory feeder with splashback up to 15 mm.

4.5 Mains connection

- 100 - 120 V, 50/60 Hz
- 220 - 240 V, 50/60 Hz
- Mains voltage fluctuations +/- 10%

4.6 Rated Power

500 VA

Ensure that the voltage and frequency of your mains connection correspond to the type plate on the machine. The mains connection must at least be protected by a 16 A fuse.

4.7 Motor Rotation Speed

The speed is 18 to 53 rpm.

4.8 Emissions

CAUTION

C6.0020

Risk of injury caused by the failure to hear acoustic signals

Loud noise during the division process

- Loud noise during the division process may lead to the inability to hear acoustic warning signals, and this can result in injuries.
- **Take volume during the division process into consideration when designing the acoustic signals in the work environment.**
- **Where necessary, introduce additional visual signals.**

4.8.1 Noise levels

Noise measurement in accordance with DIN 45635-31-01-KL3

The noise values are mainly influenced by the machine speed, the material being ground and the grinding set.

Workplace-related emissions value L_{pAeq} = up to 75 dB(A)

Sound power level LWA = 98dB(A)

Measurement conditions:

Continuous module

Grinding material: 5000 ml sand, particle size <1 mm

Sound level meter: Brüel & Kjaer 2237 Controller

4.9 Degree of Protection

- IP50

4.10 Protective Equipment

The machine can only be operated when closed. Opening the door results in the machine coming to a halt. It can only be restarted by closing the door again.

4.11 Dimensions and Weight

Height:	Up to approx. 1810 mm
Width (open):	2200 mm
Depth:	Up to approx. 1400 mm
Weight :	Net approx. 220 kg

4.12 Required Floor Space

Height:	Up to approx. 1810 mm
Width (open):	2200 mm
Depth:	Up to approx. 1400 mm

4.13 Installation drawing

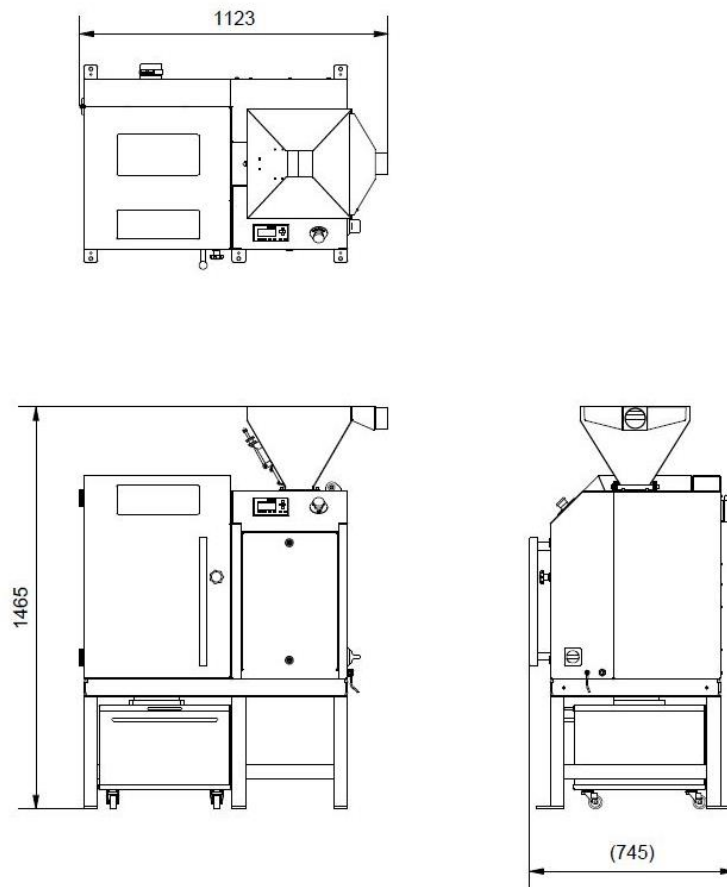

Fig. 3: Enclosure door is closed – feed hopper 30 litres

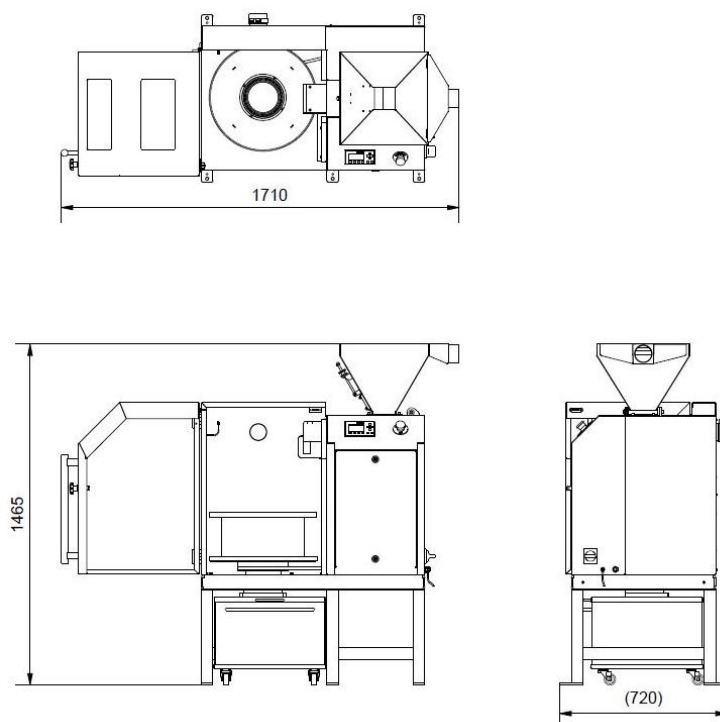

Fig. 4: Enclosure door is open – feed hopper 30 litres

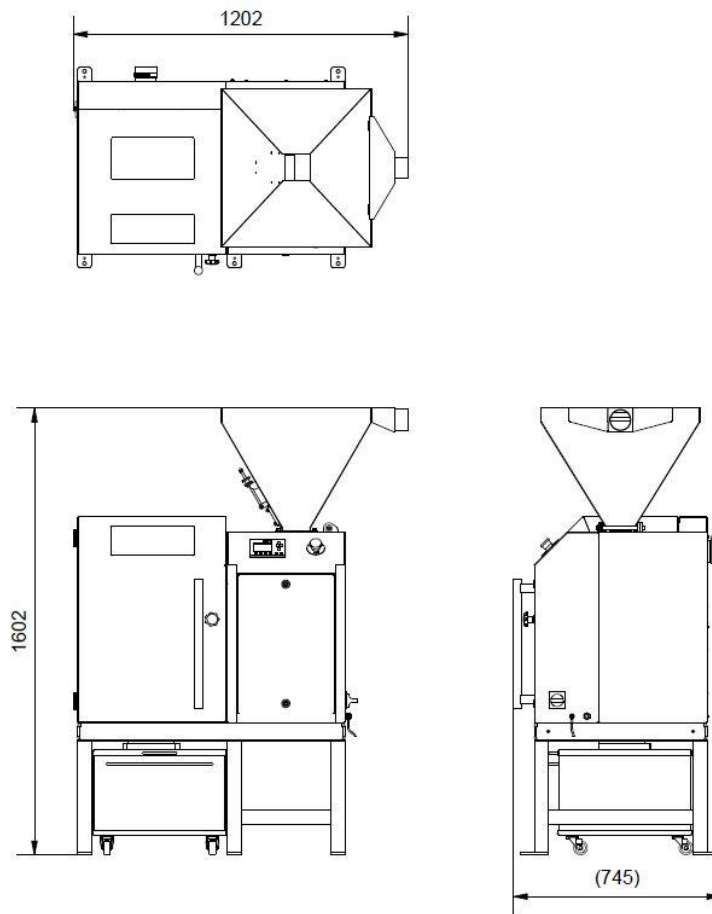

Fig. 5: Enclosure door is closed – feed hopper 60 litres

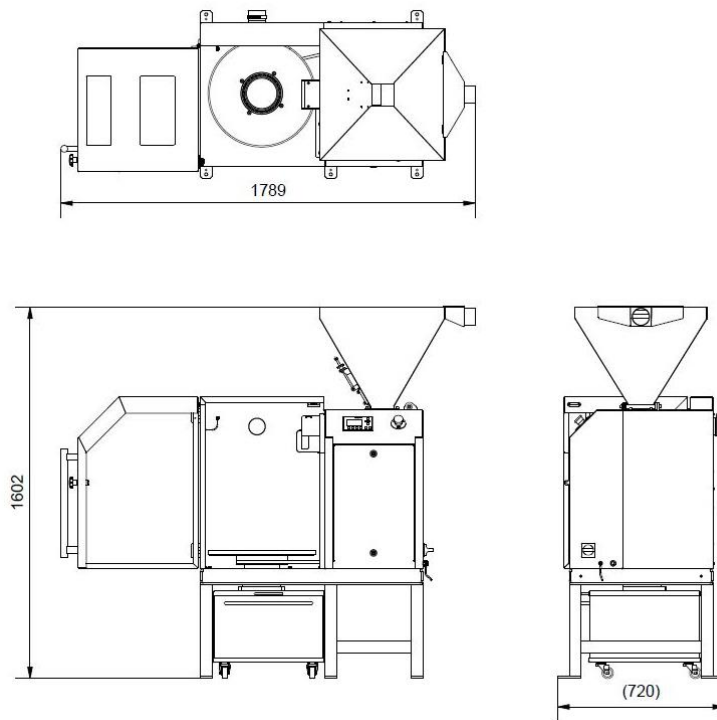

Fig. 6: Enclosure door is open – feed hopper 60 litres

5 Views of the device

5.1 Front view



Fig. 7: Front view

Element	Description	Function
A	Dust extraction for hopper	For connecting a dust extraction mechanism using a special adapter.
B	Hopper	For filling the material.
C	Knurled screw for gap size adjustment	For regulating the material flow.
D	Emergency stop button	To shut the machine down immediately in an emergency.
E	Control panel	To control the machine.
F	Hand wheel	Locks the housing door.

G	Housing door	Closes the dividing area.
H	Electrical connection	For connecting the machine to the power supply.

5.2 Interior view

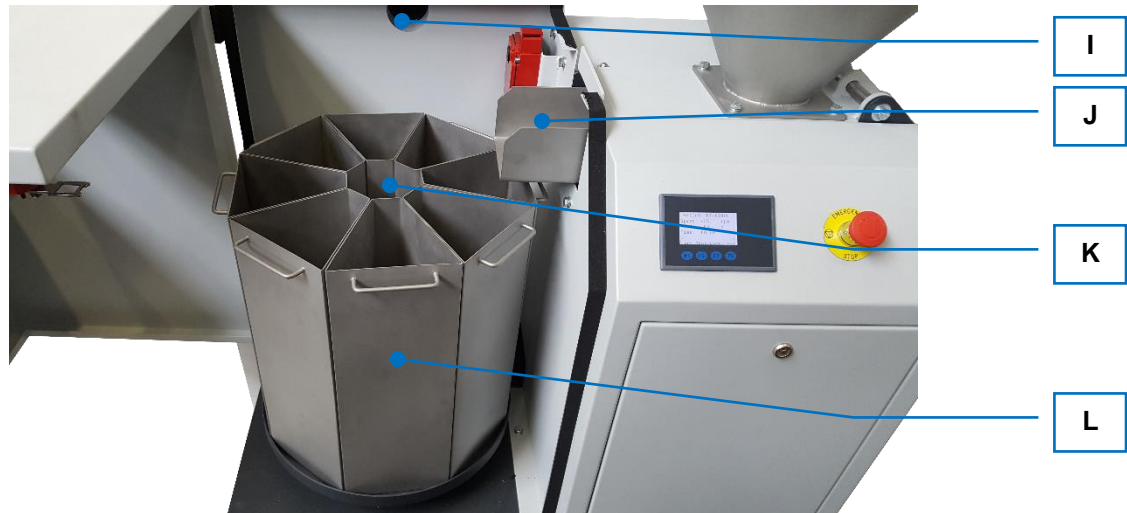

Fig. 8: Interior view

Element	Description	Function
I	Dust extraction for dividing area	To connect a dust extraction mechanism using a special adapter.
J	Vibratory feeder	Conveys the material into the dividing area.
K	Divider module	For the continuous or batch division of materials.
L	Segment	Collects the divided material.

5.3 Operating elements and displays



Fig. 9: View of the control panel

Element	Description	Function
M	Control buttons	For selecting the settings for the division process.
N	Display	Displays the control functions and parameters.

6 Operating the device

⚠ CAUTION

C7.0006

Risk of injury

Sample material that is harmful to health

- Sample material that is harmful to health can injure people (illness, contamination).
- **Use suitable extraction systems with sample material that is harmful to health.**
- **Use suitable personal protective equipment with sample material that is harmful to health.**
- **Take note of the safety data sheets for the sample material.**



6.1 Opening the device



Fig. 10: Opening the housing door

- Turn the hand wheel (F) anticlockwise to unlock and open the housing door (G).

6.2 Closing the device



Fig. 11: Closing the housing door

- Turn the hand wheel (F) clockwise to close and lock the housing door (G).

6.3 Preparing the division process

6.3.1 Inserting the riser for divider modules

The riser only has to be used if divider modules are used for batchwise allocation of up to 30 litres!

Divider modules which are used in batches of up to 30 litres have a low edge height, which means that the drop height between the vibratory feeder and part module is too high. In order to reduce the drop height inside the device and ensure process accuracy, these divider modules must be positioned on an elevation. The riser is included in the scope of delivery of the device.

- Place the elevation (K.1) in the dividing area.
- Place the partial segments (L) for the allocation of up to 30 litres for batch application in the centre of the riser.
- Continue as usual or follow the instructions in Section “Inserting the divider module”.

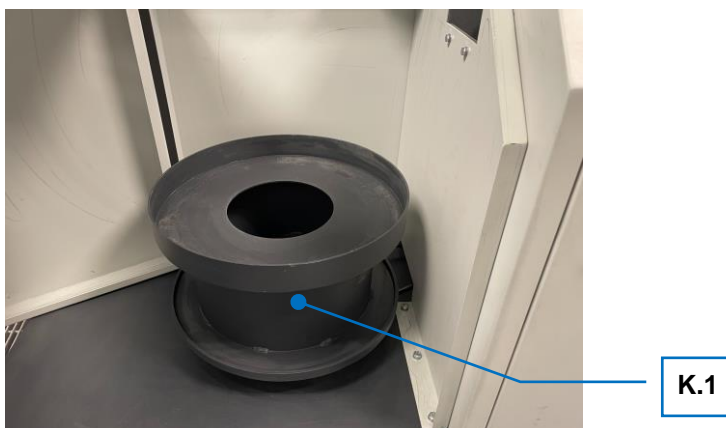

Fig. 12: Riser for divider modules for the allocation of up to 30 litres, batchwise application

6.3.2 Inserting the divider module

NOTICE

N13.0066

Wear or damage to the machine

Operation without a divider module and overloading

- Operating the machine without a divider module may lead to increased wear or damage to the machine.
- **Always operate the machine with a divider module.**
- **Do not overload the machine. Check the amount of material in the segments of the divider module regularly while the machine is running.**

The procedure described below for inserting the divider module differs depending on the type of sample division.

The following applies to divider modules which are used for continuous allocation:

- Place the desired divider module (K) for continuous application in the dividing area
- Load the divider module (K) with the respective number of segments (L) corresponding to the required division quantity of the material

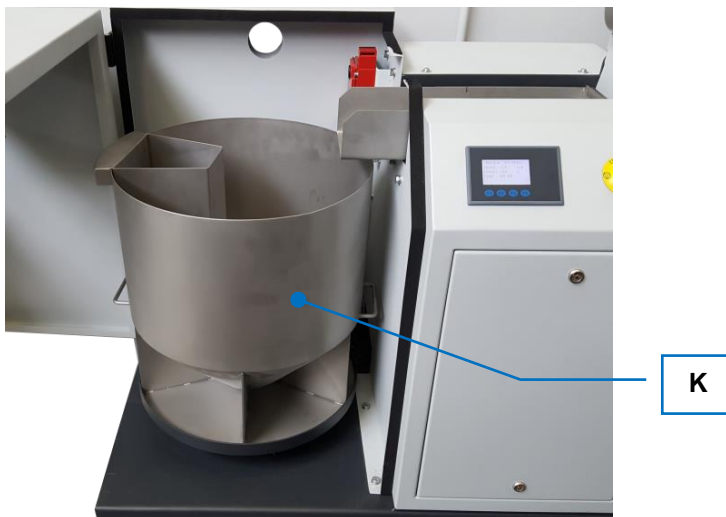

Fig. 13: Continuous divider module with one segment

The following applies to divider modules which are used for batchwise allocation:

- Place the required number of partial segments (L) for batchwise application in the dividing area. The number of segments corresponds to the required division quantity of the material.
- Partial segments made of stainless steel are joined together by using connecting plates.
- Partial segments made of aluminium are hooked into each other and secured together in the centre with an additional cover.

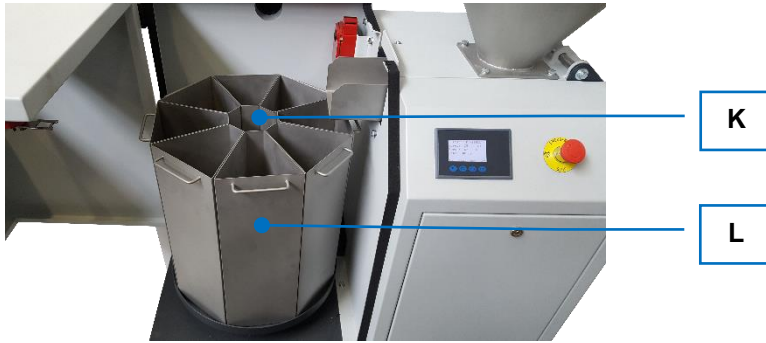

Fig. 14: Batch divider module with eight segments



Fig. 15: Connection of partial segments by using connecting plates



Fig. 16: Connection of partial segments by means of hooking them into each other

6.3.3 Inserting the vibratory feeder

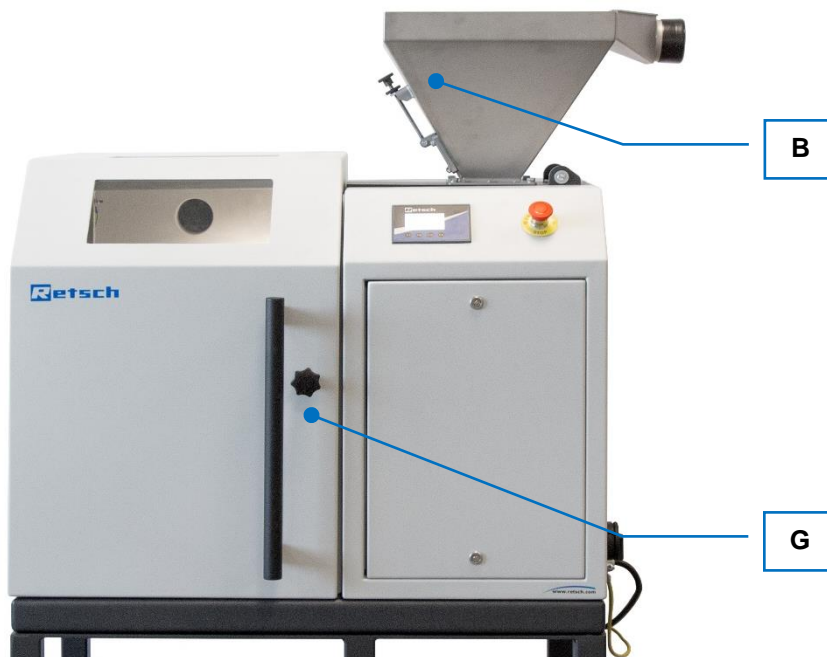

Fig. 17: Hopper

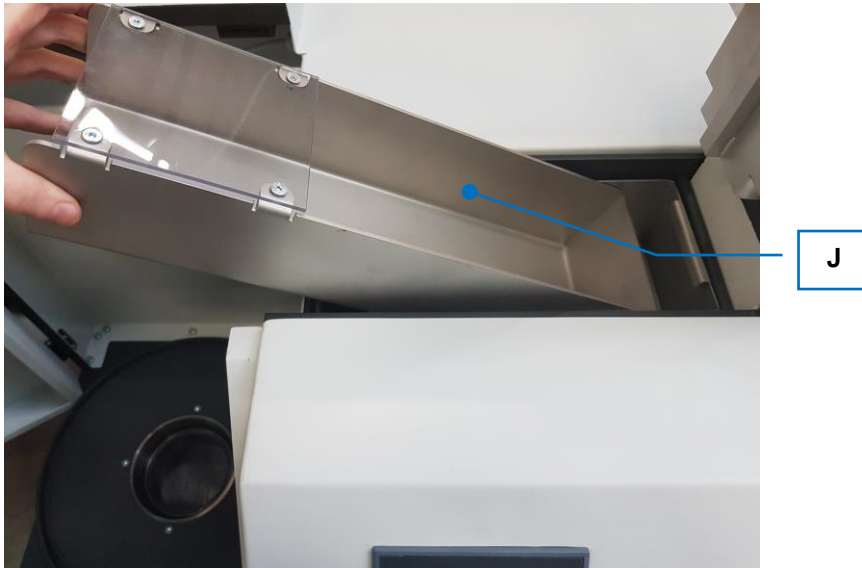

Fig. 18: Inserting the vibratory feeder

- Open the housing door (G) and swing the hopper (B) to one side in order to insert the vibratory feeder (J) into the slot.
 - Slide the vibratory feeder (J) as far as it will go into the slot.
 - Springs at the side secure the vibratory feeder (J) in the correct position.
 - Shut the hopper (B) again and close the housing door (G).
- ① For material with a feed size between 15 mm and 30 mm, the standard vibratory feeder shall be used (included in the standard scope of delivery).
For material with a feed size of less than 15 mm, the optionally available fine product vibratory feeder is recommended.



Fig. 3: Device with standard vibratory feeder



Fig. 19: Standard vibratory feeder (left), fine product vibratory feeder (right)

6.3.4 Adjusting the gap size

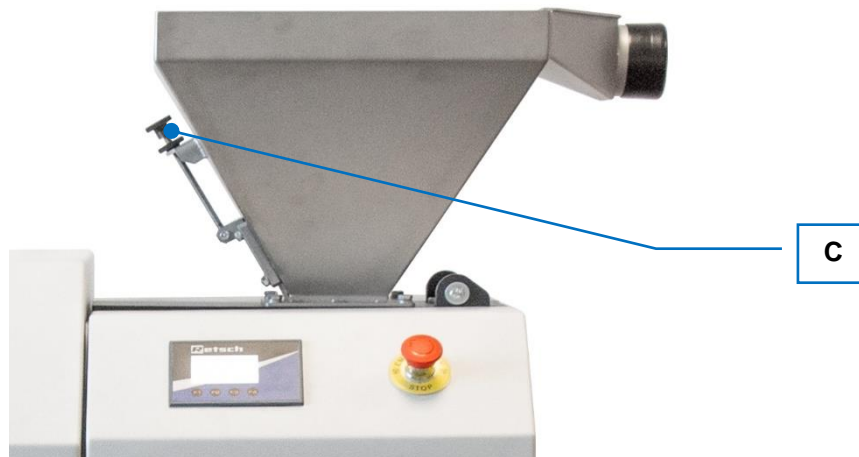

Fig. 20: Adjusting the gap size

- Using the knurled screw (C), adjust the gap size according to the feed size of the material.
- ① Adjust the gap size so that the gap is three times as big as the coarsest material particle. The material will otherwise get wedged in the hopper.

6.3.5 Connecting the dust extraction

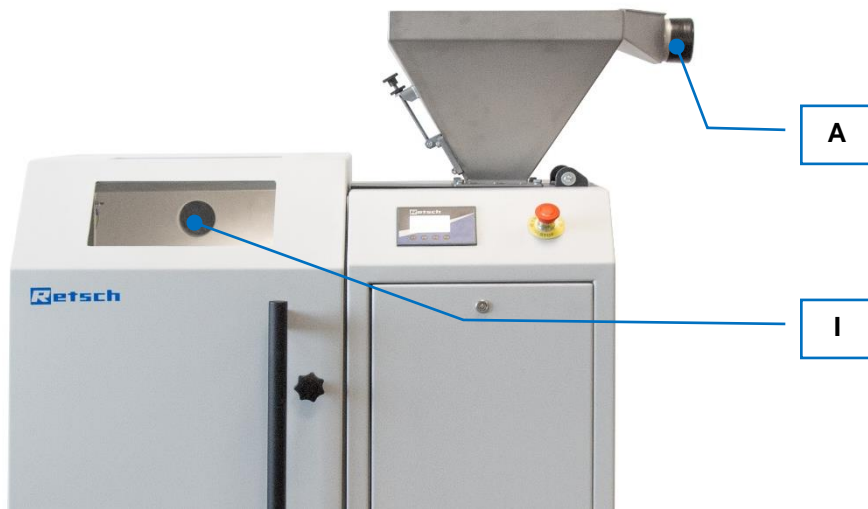

Fig. 21: Dust extraction

- Connect a dust extraction mechanism to the hopper (A) or the dividing area (I) if the properties of the material so require.
- ① A special adapter for connecting a dust extraction mechanism is available from Retsch GmbH.

6.4 Control panel – Operating the machine

6.4.1 Start menu

Press any function key.



Fig. 22: Start menu – machine is not ready for use



Fig. 23: Start menu – machine is ready for use

F1:	Start	Starts the division process.
F2:	Stop	Stops the division process.
F3:	Lock	Switches to ready for use. “Ready” appears in the display once the housing door has been locked using the hand wheel. The division process can be started by pressing F1.
F4:	Set	Opens the settings.

6.4.2 Settings

Select F4 to go to the menu settings .

The division process can be configured using this menu.

The display then shows the following functions:



Fig. 24: Settings selection menu 1/3

Runtime (duration of the division process)		
F1:	+1	Extends the duration of the division process.
F2:	- 1	Shortens the duration of the division process
F3:	m/s	Switches between the minutes/seconds setting

F4: Next	Opens the next page of the menu.
------------------------	----------------------------------

- ① The duration of the dividing process should be long enough in order to divide the entire sample volume. Representative part samples can only be assumed if the entire sample volume in the hopper is divided.

After pressing F4 the following setting appears on the display:



Fig. 25: Settings selection menu 2/3

In this menu you can specify the desired number of revolutions per minute to be implemented by the divider module.

Speed (number of revolutions of the divider module)		
F1:	+1	Increases the speed.
F2:	-1	Reduces the speed.
F3:		<i>No function in this selection menu.</i>
F4:	Next	Opens the next page of the menu.

Pressing F4 displays the following setting:

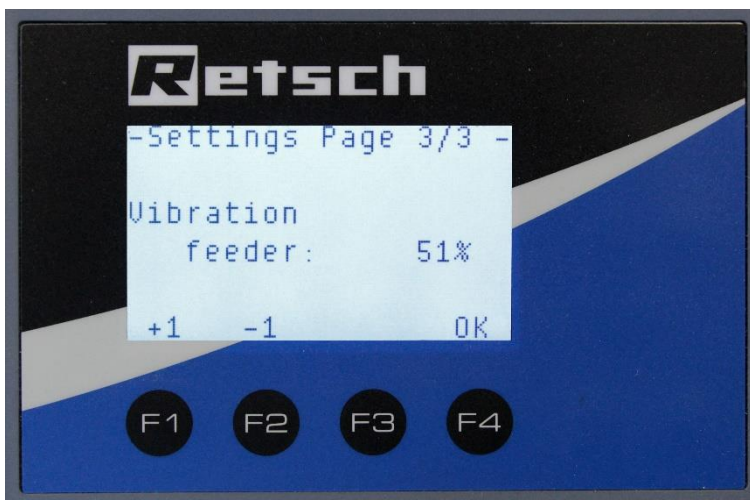

Fig. 26: Settings selection menu 3/3

In this menu you can specify the vibration intensity of the vibratory feeder during the division process.

Vibration feeder (vibration strength of the vibratory feeder)		
F1:	+1	Increases the vibration intensity.
F2:	-1	Reduces the vibration intensity.
F3:		<i>No function in this selection menu.</i>
F4:	OK	To the start menu

- ① The vibration intensity should be selected in such a way that a uniform sample flow is ensured. The sample flow can be observed through the housing windows and, if required, the vibration intensity can be adjusted during the operation.

After confirming, you go back to the start menu .



Fig. 27: Start menu –Starting the division process

Press F1 to start the division process.

6.4.3 Starting the division process

Once you have started the division process by pressing F1, the display initially shows the following view.

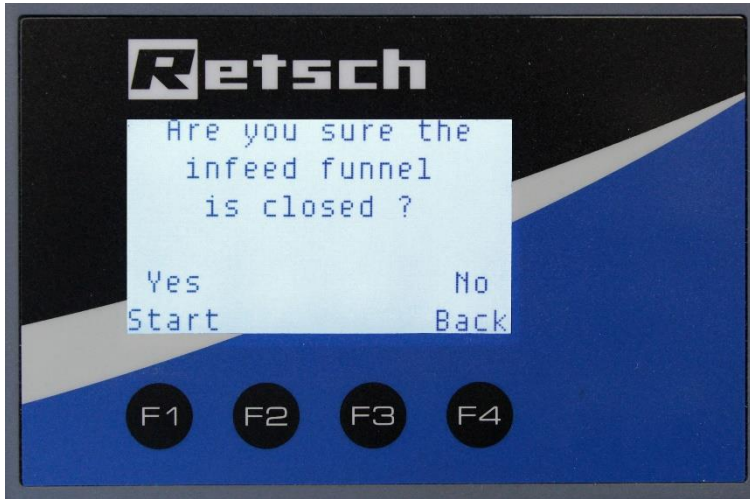

Fig. 28: Display after starting the division process

If the hopper (funnel) has been closed, confirm the safety query by pressing F1. The division process will then start.

If the hopper has not been closed, confirm the safety query by pressing F4. The division process will then not be started, and you will return to the start menu .

The display shows the following view after the division process has been started by pressing F1.



Fig. 29: Display during the division process

The display shows information about the current division process:

Speed	Speed (in rpm)	Provides information about the set speed of the divider module.
Feeder	Vibration intensity (in %)	Provides information about the set vibration intensity of the vibratory feeder.
Time	Time (in minutes and seconds)	Provides information about the time left until the division process has been completed.

The division process can be ended at any time by pressing F2.

6.5 Finishing the division process



Fig. 30: Front view

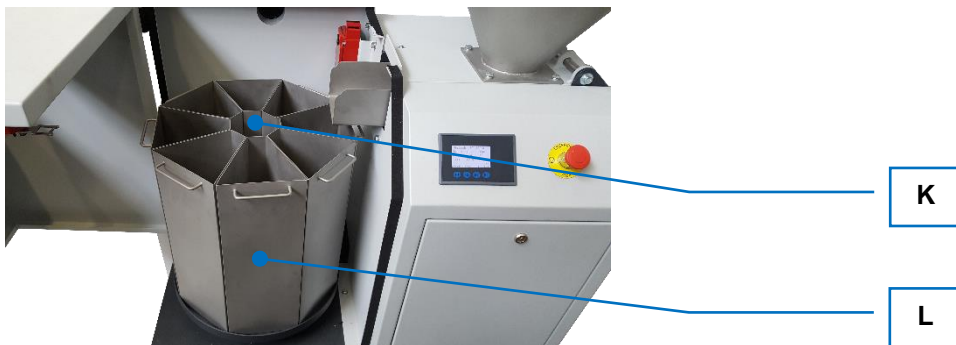

Fig. 31: Interior view

- Once the division process has finished, unlock the housing door (G) using the hand wheel (F).

- Open the housing door (G).
 - Remove the segments (L) with the material individually from the divider module (K).
- ① The collecting receptacle beneath the dividing area has been filled when using the continuous divider module.

7 Error messages

Error messages inform the user about detected machine or program errors. An error message indicates the presence of a fault which automatically interrupts operation of the machine or program. Faults of this kind must be rectified before the machine is started up again.

Error code	Description	Actions
E26	Frequency converter error	<ul style="list-style-type: none"> • Turn the main switch off and wait for 30 seconds before turning the machine back on again. • Make certain that the drum is not too full. • If the error persists, contact Customer Service at Retsch GmbH.
E40	Positioning mode error	<ul style="list-style-type: none"> • The machine stops automatically without moving to the end position. • Acknowledge the message and start the machine again or use the SLS mode to move the drum manually into the desired position. • If the error persists, contact Customer Service at Retsch GmbH.
E51	Emergency stop error	<ul style="list-style-type: none"> • Release the emergency stop switch. • If the error persists, contact Customer Service at Retsch GmbH.

8 Cleaning, Wear and Maintenance



8.1 Cleaning

⚠ WARNING

W5.0003

Risk to life caused by an electric shock
Cleaning live parts with water

- Cleaning the device with water can lead to life-threatening injuries caused by an electric shock if the device has not been disconnected from the power supply.
- **Only carry out cleaning work on the device when it has been disconnected from the power supply.**
- **Use a cloth moistened with water for cleaning.**
- **Do not clean the device under running water!**

⚠ CAUTION

C8.0013

Risk of injury
Improper repairs

- Unauthorised and improper repairs can cause injuries.
- **Repairs to the device may only be carried out by Retsch GmbH, an authorised representative or by qualified service technicians.**
- **Do not carry out any unauthorised or improper repairs to the device!**

NOTICE

N14.0009

Damage to the housing and device
Use of organic solvents

- Organic solvents may damage plastic parts and the coating.
- **The use of organic solvents is not permitted.**

8.1.1 Cleaning the machine housing

⚠ WARNING The device must always be switched off and disconnected from the mains before accessing it for cleaning or servicing purposes.

⇒ Clean the housing of the device with a damp cloth and, if necessary, a household cleaning agent. Make sure that no water or cleaning agent gets into the interior of the device.

⇒ Only use neutral cleaning agents. Do not use solvent-based cleaners! Acetone is not permitted!

Test cleaning products on an inconspicuous spot.

8.1.2 Cleaning the feed hopper and the interior

⚠ WARNING The device must always be switched off and disconnected from the mains before accessing it for cleaning or servicing purposes.

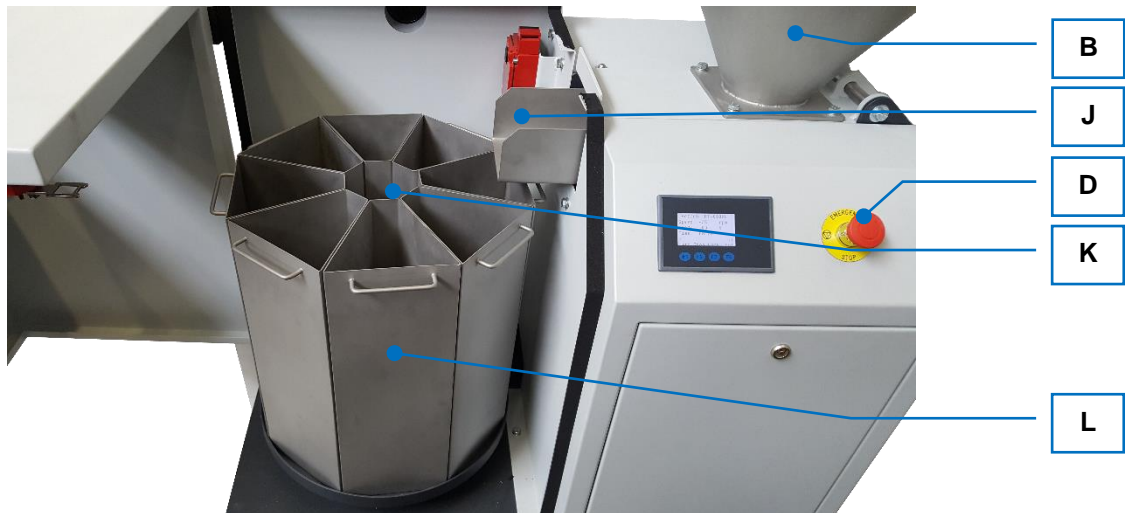

Fig. 32: Cleaning

- Switch off the device with the emergency stop button (D).
- Disconnect the unit from the power supply and secure the device against being switched on again.
- Open the enclosure door and fold the funnel (B) to the side.
- If necessary, remove the part module (K) as well as the segments (L) and the vibratory feeder (J) from the interior.
- Clean the funnel, the part module, the segments and the vibratory feeder with a damp cloth and, if necessary, a household cleaning agent.

8.2 Wear

CAUTION

C9.0013

Risk of injury

Improper repairs

- Unauthorised and improper repairs can cause injuries.
- **Repairs to the device may only be carried out by Retsch GmbH, an authorised representative or by qualified service technicians.**
- **Do not carry out any unauthorised or improper repairs to the device!**

8.3 Maintenance

CAUTION

C10.0013

Risk of injury

Improper repairs

- Unauthorised and improper repairs can cause injuries.
- **Repairs to the device may only be carried out by Retsch GmbH, an authorised representative or by qualified service technicians.**
- **Do not carry out any unauthorised or improper repairs to the device!**

9 Return for Service and Maintenance



Fig. 33: Return form

The acceptance of devices and accessories of the Retsch GmbH for repair, maintenance or calibration can only be effected, if the return form including the decontamination declaration service has been correctly and fully completed.

- ⇒ Download the return form located in the download section "Miscellaneous" on the Retsch GmbH homepage (<http://www.retsch.com/downloads/miscellaneous/>).
- ⇒ When returning a device, attach the return form to the outside of the packaging.

In order to eliminate any health risk to the service technicians, Retsch GmbH reserves the right to refuse the acceptance and to return the respective delivery at the expense of the sender.

10 Disposal

In the case of a disposal, the respective statutory requirements must be observed. In the following, information on the disposal of electrical and electronic devices in the European Community are given.

Within the European Community the disposal of electrically operated devices is regulated by national provisions that are based on the EU Directive 2012/19/EU on Waste Electrical and Electronic Equipment (WEEE).

Accordingly, all devices supplied after August 13th 2005 in the business-to-business area, to which this product is classified, may no longer be disposed of with municipal or household waste. To document this, the devices are provided with the disposal label.

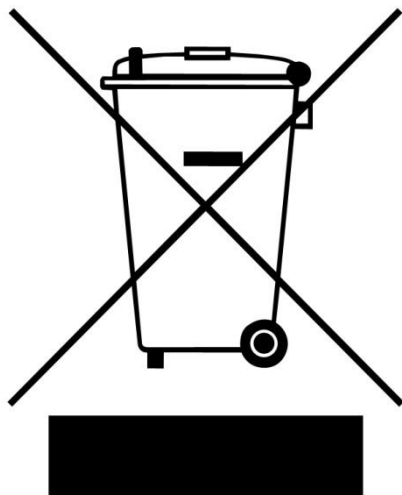

Fig. 34: Disposal label

Since the disposal regulations worldwide and also within the EU may differ from country to country, the supplier of the device should be consulted directly in case of need.

This labelling obligation is applied in Germany since March 23rd 2006. From this date on, the manufacturer must provide an adequate possibility of returning all devices delivered since August 13th 2005. For all devices delivered before August 13th 2005 the end user is responsible for the proper disposal.

Information on available accessories as well as the respective manuals are accessible directly on the Retsch GmbH homepage (<https://www.retsch.com>) under the heading "Downloads" of the device.

Information on wear parts and small accessories can be found in the Retsch GmbH general catalogue also available on the homepage.

In case of any questions concerning spare parts please contact the Retsch GmbH representative in your country, or Retsch GmbH directly.

11 Index

- 5**
500 VA 19
- A**
Adjusting the gap size..... 31
All current sensitive..... 14
Ambient temperature 13
Amendment status..... 6
Amperage 17
Anti-interference circuit 14
Assembly personnel 10
- B**
Bar code 17
Batch divider module 29
- C**
Calibration..... 42
Capacity 17
CE marking 17
Cleaning..... 40
Cleaning the feed hopper and the interior 40
Cleaning the machine housing 40
Closing the device 27
Closing the machine 27
Complaints..... 12
Condensation..... 12
Confirmation form for the managing operator..... 11
Connecting the dust extraction 32
Continuous divider module 28
Control buttons 25
Control panel 23, 32
Copyright 6
- D**
Degree of protection 20
Depth 20
Device designation 17
Dimensions 20
DIN 45635-31-01-KL3..... 20
Disclaimer 6
Display 25
Disposal 43
 label..... 43
 regulations..... 43
Disposal label 17
Divider module 24
Divider modules 19
Dust extraction..... 32
Dust extraction for dividing area 24
Dust extraction for hopper 23
- E**
Electrical connection..... 14, 24
EMC Directive..... 14
Emergency stop button..... 23
Emissions 20
Error messages 39
E26 39
E40 39
E51 39
Explanations of the safety instructions 7
External fuse 14
- F**
Feed size 19
Fine product vibratory feeder..... 31
Finishing the division process..... 37
Frequency 14
Frequency converter 14
Front view 23, 37
Funnel 19
Fuse strength 17
Fuse type 17
- G**
Gap size adjustment 23
General catalogue..... 43
General safety instructions 8
- H**
Hand wheel 23
Hearing loss 18
Height..... 20
Hopper 23, 29
Housing door..... 24
Humidity 13
- I**
Inserting the divider module..... 28
Inserting the riser for divider modules..... 27
Inserting the vibratory feeder 29, 30
Installation 12
Installation drawing 21
Installation height 13
Installation site
 conditions 13
Installing the device 16
Intended use of the device..... 18
Interior view..... 24, 37
- L**
Long-term operation..... 19
LpAeq..... 20
LWA 20
- M**
Mains connection 14, 19
Mains frequency..... 17
Mains supply 14
Maintenance 11, 40, 41, 42
Manual 6, 8, 11
Manufacturer's address 17
Maximum relative humidity 13
Motor rotation speed 20

N	
Noise levels	20
Noise measurement.....	20
Noise values	20
Notes on the manual.....	6
O	
Opening the device	26
Opening the housing door	26
Operating company	10
Operating elements and displays	25
Operating instructions.....	11
Operating the device.....	26
Operation	15
Operators	9
Organic solvents	40
P	
Packaging	12
Part number	17
Personnel qualification and target group of this manual.....	10
Power version	17
Preparing the division process	27
Protective equipment	20
R	
Range of application of the device	19
Rated power	19
Repair	9, 40, 41, 42
Repair instructions	9
Required floor space.....	20
Residual current device	14
Responsibility of the operating company	9
Return	12
for service and maintenance	42
Return device.....	43
Return form.....	42
S	
Safety.....	7
Safety Officer	7
Segment	24
Selection menu	33, 34
Serial number	17
Service address	9
Settings	33, 34
Shielded cable	14
Small accessories	43
Sound level	18
Sound level meter	20
Sound power level	20
Spare parts	43
Standard vibratory feeder	31
Start menu	32, 33, 35, 36
Starting the division process.....	35, 36
T	
Target group	7
Technical data.....	18
Temperature fluctuations	12
Temperature range	13
Temporary storage.....	12
Transport.....	12, 15
Transport damage.....	12
Transport lock	16
Transportation lock	15
Trip current.....	14
Type plate	14, 17
description	17
U	
UKCA marking	17
V	
Vibratory feeder	24
View of the control panel	25
Views of the device	23
Voltage	14
W	
Warning.....	7
Information	8
Warranty claim	12
Warranty claims	9
Wear.....	28, 40, 41
Wear parts	43
Weight.....	17, 20
Width.....	20
Workplace-related emissions value	20
Y	
Year of production.....	17

ROTATING SAMPLE DIVIDER

PT 300 | 41.005.xxxx

EU DECLARATION OF CONFORMITY

We, represented by the undersigned, hereby declare that the above device complies with the following directives and harmonised standards:

Machinery Directive 2006/42/EC

Applied standards, in particular:

DIN EN ISO 12100	Machine Safety - General Design Principles
DIN EN 60204-1	Safety of machinery – Electrical equipment of machines
DIN EN ISO 13849-1	Safety of machinery - Safety-related parts of control systems

Electromagnetic compatibility 2014/30/EU (tested at 230 V, 50 Hz)

Applied standards, in particular:

EN 55011	Industrial, scientific and medical equipment - Radio-frequency disturbance characteristics - Limits and methods of measurement
DIN EN 61326-1	Electrical equipment for measurement, control and laboratory use - EMC requirements

Restriction of hazardous substances (RoHS) 2011/65/EU

Authorised person for compilation of the technical documentation:

Julia Kürten (Technical Documentation)

Furthermore, we declare that the relevant technical documentation for the above device has been prepared in accordance with Annex VII Part A of the Machinery Directive and we undertake to submit the documentation to the market surveillance authorities on request.

In the event of a modification of the device not agreed on by Retsch GmbH, as well as the use of non-approved spare parts or accessories, this declaration loses its validity.

Retsch GmbH

Haan, 07/2024



Dr. Stefan Mähler, Technical Manager





Retsch[®]

Copyright

© Copyright by
Retsch GmbH
Retsch-Allee 1-5
42781 Haan
Germany